

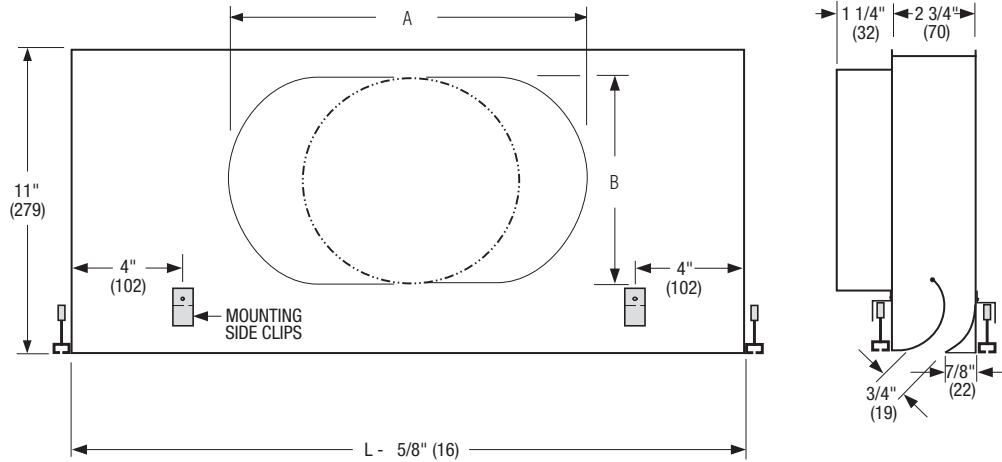

N SERIES PLENUM SLOT DIFFUSER
SUPPLY • PREMIUM PERFORMANCE
HORIZONTAL DISCHARGE
FINELINE® /BOLT-SLOT CEILING
MODEL: 59N-H11-FNL



Nominal Length L	Available Inlet Sizes
24 (600)	6 (152) Round
48 (1219)	8 (203) Round 10 (254) Oval

T-Bar Type (Manufacturer)	X	Y
A Armstrong Silhouette	1 3/4 (44)	5/16 (8)
C Chicago Metallic Ultraline	1 5/8 (41)	5/16 (8)
D Donn Fineline	1 25/32 (45)	5/16 (8)

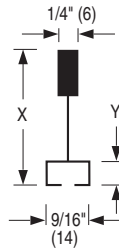

Nominal Inlet Size	Dimension	
	A	B
6 (152) Round	-	5 7/8 (149)
8 (203) Round	-	7 7/8 (200)
10 (Oval) Round	11 (279)	7 7/8 (200)

DESCRIPTION:

- The 59N Type FNL Plenum Slot Ceiling Diffusers have been designed for for Fineline® type Bolt Slot suspended ceiling grids. The 48" (1219) long unit is not available with a cross notch (for 2' x 2' grids).
- The 59N design provides premium performance. An aerodynamic extruded aluminum pattern controller provides a fixed horizontal discharge and produces a tight blanket of air into the room, maximizing coanda effect and induction of room air.
- The design is excellent for VAV, heating and cooling applications.
- Standard nominal lengths are 24" or 48" to suit imperial ceiling grids. Metric units are available.
- Plenum is corrosion resistant steel.
- Finish: BK Black pattern controllers and exposed edges.

ACCESSORIES (See submittal 59N-ACC)

- FS** Diamond Flow Sensor with extended collar and bead (6" and 8" round inlet only)
- EX** 1/2" (13) External foil back insulation
- EX1** 1" (25) External foil back insulation
- EC** 3" (76) Extended inlet collar

SCHEDULE TYPE:	Dimensions are in inches (mm).			
PROJECT:				
ENGINEER:	DATE	B SERIES	SUPERSEDES	DRAWING NO.
CONTRACTOR:	6 - 9 - 08	5900	NEW	59N-H11-FNL