

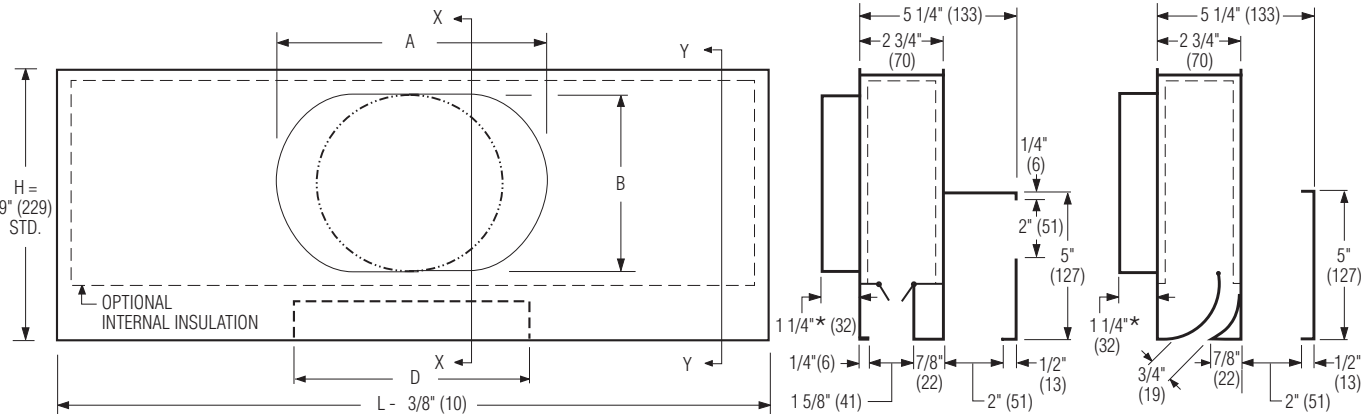

N SERIES PLENUM SLOT DIFFUSER
SUPPLY / RETURN • PREMIUM PERFORMANCE
HORIZONTAL / VERTICAL DISCHARGE
MODEL: 59NDR (I)



SECTION X-X
SR STANDARD SIDE INLET
RETURN ILLUSTRATED

SECTION Y-Y
TR OPTIONAL TOP INLET
RETURN ILLUSTRATED

* 4" (102) with optional ID Inlet Damper

Nominal Length L		Available Down-Blow Slot Dim. D	Available Inlet Sizes
Imperial Modules	Metric Modules		
24 (610)	600	8, 12 (203, 305)	6, 8, 10 (152, 203, 254)
36 (914)	900	12, 15 (305, 381)	
48 (1219)	1200	12, 15, 18 (305, 381, 457)	
60 (1524)	1500	15, 18, 21 (381, 457, 533)	

Nominal Inlet Size	Dimension (H9)	
	A	B
6 (152) Round	—	5 7/8 (149)
8 (203) Oval	9 (229)	5 7/8 (149)
10 (254) Oval	12 1/8 (308)	5 7/8 (149)

DESCRIPTION:

- The 59NDR Supply/Return Plenum Slot Ceiling Diffusers have been designed for standard lay-in T-Bar application.
- The 59NDR design provides two air patterns and premium performance in perimeter curtain wall application. An aerodynamic extruded aluminum pattern controller provides a fixed horizontal discharge and produces a tight blanket of air into the room, maximizing coanda effect and induction of room air. A central down-blow section which incorporates two pattern controllers (shipped in wide open position), provides an adjustable vertical discharge along the wall or glass in perimeter applications. An integral return air section returns room air into the ceiling plenum, with minimal short-circuiting of supply air. Standard (SR) side inlet return section also acts as a light shield and prevents see through.
- The design is excellent for VAV, heating and cooling applications.
- Standard nominal lengths are 24", 36", 48" and 60" to suit imperial ceiling grids. Metric units are available. Standard H9 plenum height is 9" (229). Standard inlet sizes are 6" round, 8" and 10" flat oval.
- Plenum is corrosion resistant steel.
- Finish: BK Black pattern controllers and exposed edges.

OPTIONS:

- Internal Insulation. Model 59NDR I
- ID Inlet Damper
- PF Plaster Frame
- Supplementary T-Bars
 - T1 One (inlet side)
 - T0 One (opposite inlet side)
 - T2 Two (Both sides)
- Mounting Clips
 - M1 One side (2 opposite inlet side)
 - M2 Both sides (4)
- EX External Foil Back Insulation
- EQT Earthquake Tabs
- EC 3" (76) Extended inlet collar w/bead
- TR Top inlet return section
- Non-standard plenum height
 - H7 7" (178) high
 - H11 11" (279) high
- FS Diamond Flow Sensor w/extended collar bead. Requires H11 option. 6" and 8" round inlet sizes only. (Not available on models with internal insulation).
- SP Special features _____

SCHEDULE TYPE:				
PROJECT:				
Dimensions are in inches (mm).				
ENGINEER:	DATE	B SERIES	SUPERSEDES	DRAWING NO.
CONTRACTOR:	5 - 11 - 09	5900	11 - 2 - 07	59NDR