

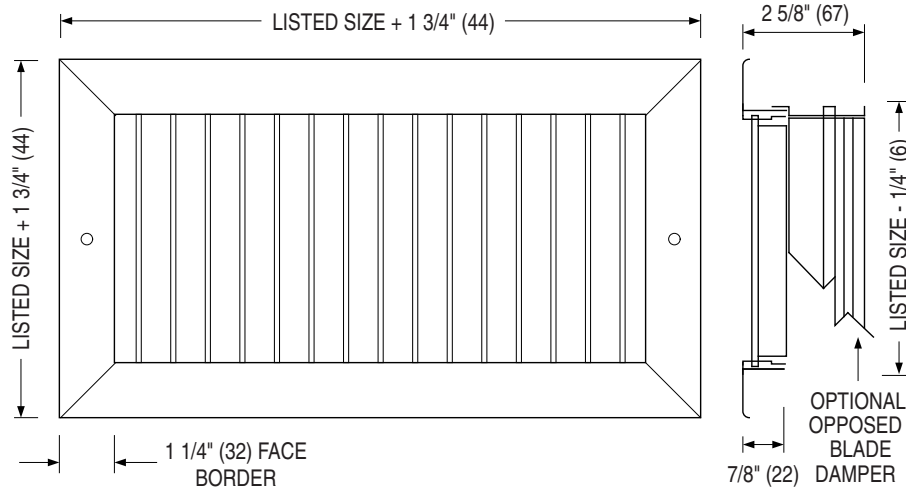

**STEEL SUPPLY GRILLES & REGISTERS
SINGLE DEFLECTION
MODELS: 61SV(-O) AND 61SH(-O) TYPE S**



MODEL 61SV
Single Deflection Grille
Vertical Blades

MODEL 61SV-O
Single Deflection Register
Vertical Blades
(Includes O. B. Damper)

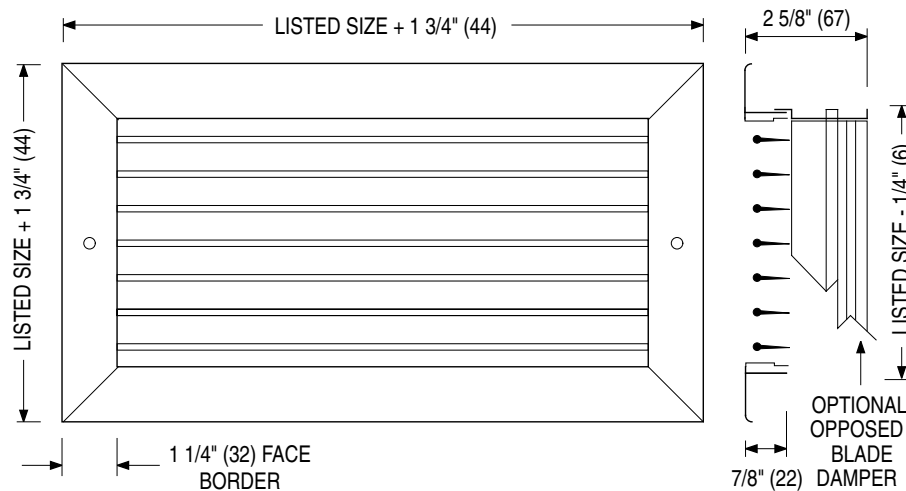

MODEL 61SH
Single Deflection Grille
Horizontal Blades

MODEL 61SH-O
Single Deflection Register
Horizontal Blades
(Includes O. B. Damper)

DESCRIPTION:

1. Construction: Corrosion resistant steel. Roll-formed frame mechanically interlocked with mitered corners for strength. A single set of roll-formed 'teardrop' blades on 3/4" (19) centers provide air control in a single plane. Blades are individually pivoted to ensure positive positioning when adjusted to desired deflection setting.
2. Optional roll-formed steel opposed blade damper has a screw driver slot operator accessible through face of register.
3. Minimum size is 4" x 4" (102 x 102).
Maximum size is 48" x 36" (1219 x 914).
4. Type S Surface mount frame has a 1 1/4" (32) face border and a 1" (25) overlap margin.
5. Standard fastening is Type A countersunk screw holes.
6. Standard finish is AW Appliance White.

OPTIONS:

1. Finish:
 - SP Special _____ .
2. Fastening:
 - Type C Concealed mounting straps
 - Type D Concealed screw holes in neck
 - Type N None.
3. PF Plaster frame
4. IS Insect screen
5. Other _____ .

SCHEDULE TYPE:

PROJECT:

ENGINEER:

CONTRACTOR:

Dimensions are in inches (mm).

DATE	B SERIES	SUPERSEDES	DRAWING NO.
2 - 1 - 11	6100	2 - 23 - 04	6100-1