

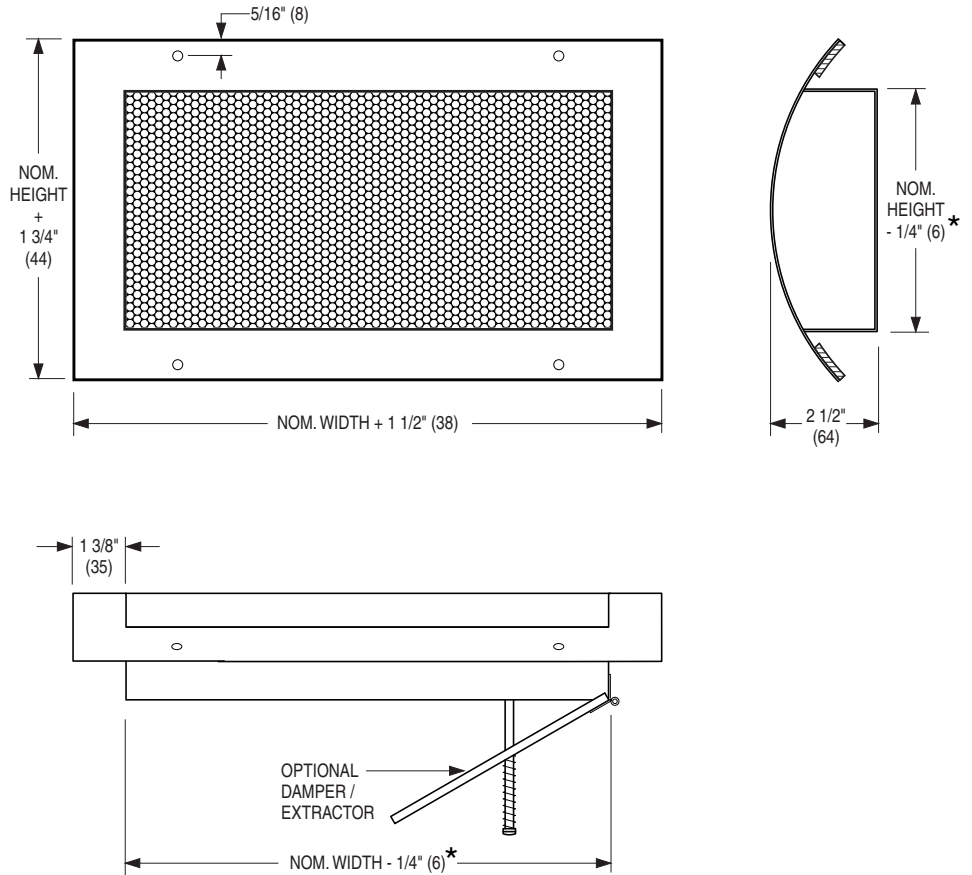

**STEEL CURVED SPIRAL DUCT GRILLES**  
 TRUE FULL RADIUS DESIGN  
 PERFORATED FACE • RETURN  
**MODELS: 61PRC**

**MODEL 61PRC**  
 Perforated Face



**Available Sizes**

Grille Width Min. - Max.	Grille Height	Duct Diameter Min. - Max.
10 - 48 (254 - 1219)	3 (76)	6 - 36 (152 - 914)
10 - 48 (254 - 1219)	4 (102)	6 - 36 (152 - 914)
10 - 48 (254 - 1219)	6 (152)	8 - 36 (203 - 914)
10 - 48 (254 - 1219)	8 (203)	10 - 36 (254 - 914)
10 - 48 (254 - 1219)	10 (254)	12 - 36 (305 - 914)
12 - 36 (305 - 914)	12 (305)	14 - 36 (356 - 914)

Duct diameters in even sizes only. Grilles available in nominal 1" (25) increments in width.

\* Opening = Nominal + 1/4" (6) with DEX Damper/Extractor option.

**Important:**

Grilles are custom fabricated to fit only a single specified duct diameter.

**DESCRIPTION:**

1. Nailor's unique curved spiral duct grille design offers an architecturally superior appearance and saves installation time and money by directly mounting to the duct and hence eliminating the need to fabricate stand-off saddles for standard grilles. The 61PRC may be used for supply and/or return air applications.
2. Construction: Unique architectural single piece corrosion-resistant steel frame design is rolled to match required duct radius, eliminating unsightly non-aligned butted corners. Perforated face has 3/16" (5) dia. holes on staggered 1/4" (6) centers. 51% free area.
3. A thick foam gasket is provided as standard to ensure a tight seal to duct.
4. Standard fastening is Type A screw holes.
5. Standard finish is AW Appliance White.

**Options:**

- DEX Damper/Extractor\* (Air scoop) (For supply air applications).
- Finish:
- AL Aluminum.
  - MI Mill.
  - SP Special. Specify \_\_\_\_\_.

<b>SCHEDULE TYPE</b>	Dimensions are in inches (mm).			
<b>PROJECT</b>				
<b>ENGINEER</b>	<b>DATE</b>	<b>B SERIES</b>	<b>SUPERSEDES</b>	<b>DRAWING NO.</b>
<b>CONTRACTOR</b>	9 - 22 - 11	6100C	4 - 12 - 11	6100C-3