

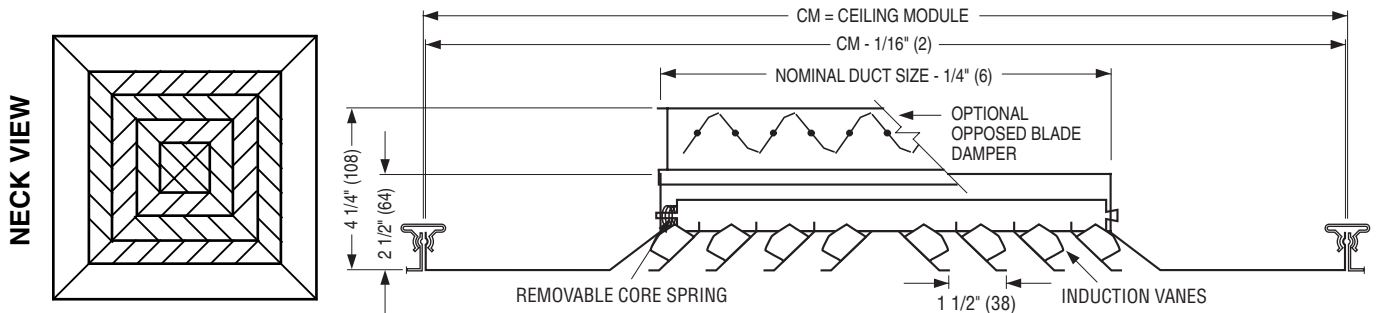

**PATTERN CEILING DIFFUSERS
WITH IV INDUCTION VANES**
ALUMINUM • SQUARE, RECT. OR ROUND NECK
MODELS: 6200IV AND 6200IV-O TYPE M

TYPE METAL PAN (SNAP-IN)



If the ceiling module is more than 3" (76) larger than the neck size of the diffuser in either or both dimensions, a steel module sized extended panel will be added.
Minimum duct size: 6 x 6 (152 x 152).
Maximum duct size: see table.
Available in 3" (76) increments only.

IMPERIAL MODULES				METRIC MODULES	
Imperial Units (in.)		Metric Units (mm)		Metric Units (mm)	
CM	Maximum Duct Size	CM	Maximum Duct Size	CM	Maximum Duct Size
12 x 12	9 x 9	305 x 305	229 x 229	300 x 300	152 x 152
24 x 12	21 x 9	610 x 305	533 x 229	600 x 300	457 x 152
24 x 24	21 x 21	610 x 610	533 x 533	600 x 600	457 x 457

CORE STYLE SELECTION

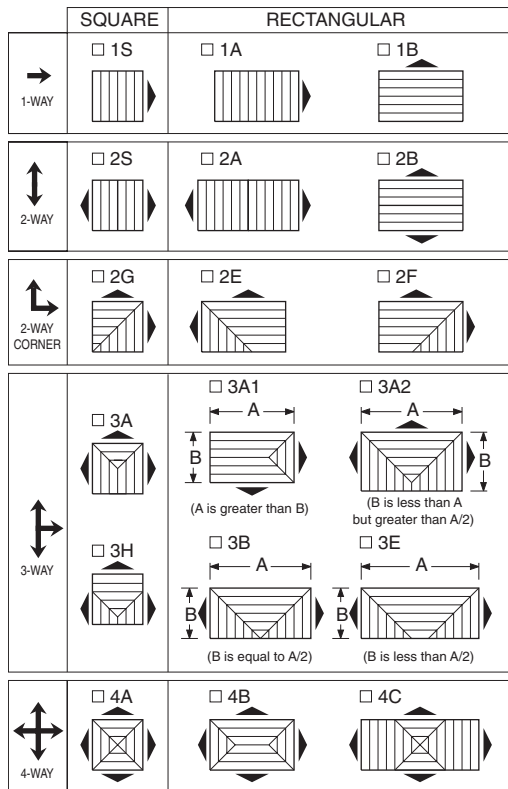

Patterns are shown in plan view (looking down into inlet).

DESCRIPTION:

1. Material: Aluminum. Extended panel where required is corrosion-resistant coated steel.
2. Model 6200IV is a high capacity ceiling diffuser available in 1, 2, 3 or 4-way blow patterns to provide a tight horizontal airflow pattern from maximum to minimum airflow. The induction vanes consist of a set of 45° angled diffusion vanes spaced 1 1/2" (38) apart on the back of each diffuser louver. Vane sets on adjacent parallel louvers run in opposite directions and cause primary air to emerge from each louver at alternating angles. The resulting turbulent discharge air jets produce high induction rates and rapid temperature equalization, making the diffuser eminently suitable for VAV applications as the possibility of downdrafts (dumping) are eliminated.
3. Spring-loaded removable core.
4. Standard finish is AW Appliance White.

OPTIONS:

- PLA Aluminum Extended Panel.
- SQUARE AND RECTANGULAR NECK**
- Steel opposed blade damper. Model 6200IV-O.
 - Aluminum opposed blade damper. Model 6200IV-OA.

ROUND NECK

- SQR Square to round transition collar
- SQR-O Square to round transition collar for use over O.B.D.
- 4275 Radial Opposed Blade Damper (round)
- 4250 Radial Sliding Blade Damper (round)
- 4675 Butterfly Damper (round)

OPTIONAL FINISH:

- SP Special. Specify _____.

Dimensions are in inches (mm).

SCHEDULE TYPE:				
PROJECT:				
ENGINEER:	DATE	B SERIES	SUPERSEDES	DRAWING NO.
CONTRACTOR:	10 - 24 - 07	6200	4 - 23 - 03	6200IV-6