

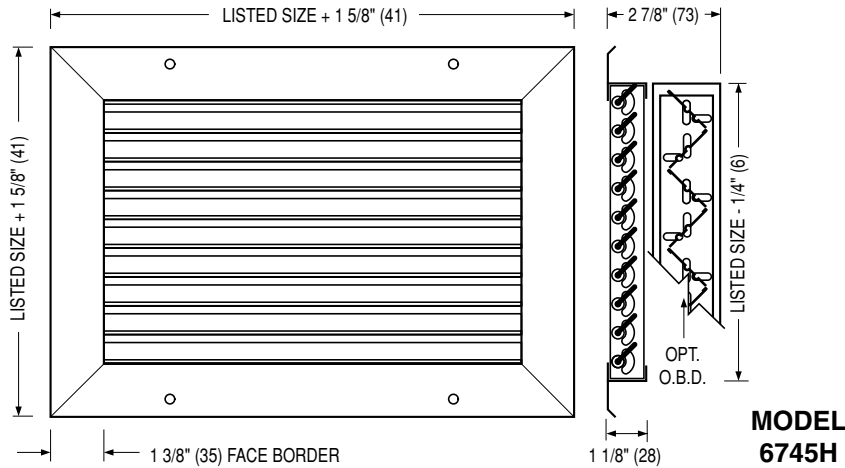

**STAINLESS STEEL RETURN GRILLES  
& REGISTERS • FIXED BLADES**  
**MODELS: 6745H(-O), 6745V(-O), 67FH(-O)**  
**AND 67FV(-O) TYPE S**

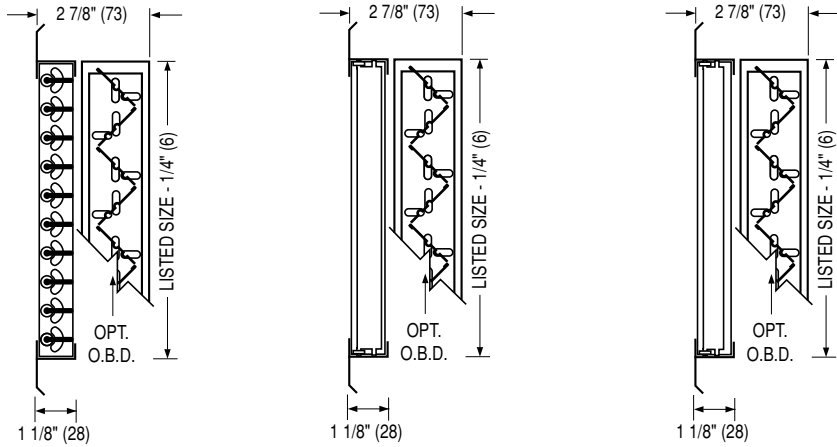

**MODEL 6745H**



**MODEL 67FH**

**MODEL 67FV**

**MODEL 6745V**

- MODEL 6745H**  
Single Deflection Grille  
Fixed 45° Horizontal Blades
- MODEL 6745H-O**  
Single Deflection Register  
Fixed 45° Horizontal Blades  
(Includes O. B. Damper)
- MODEL 6745V**  
Single Deflection Grille  
Fixed 45° Vertical Blades
- MODEL 6745V-O**  
Single Deflection Register  
Fixed 45° Vertical Blades  
(Includes O. B. Damper)
- MODEL 67FH**  
Single Deflection Grille  
Fixed 0° Horizontal Blades
- MODEL 67FH-O**  
Single Deflection Register  
Fixed 0° Horizontal Blades  
(Includes O. B. Damper)
- MODEL 67FV**  
Single Deflection Grille  
Fixed 0° Vertical Blades
- MODEL 67FV-O**  
Single Deflection Register  
Fixed 0° Vertical Blades  
(Includes O. B. Damper)

**DESCRIPTION:**

1. Construction: Type 304 stainless steel welded and reinforced frame features hairline mitered corners. Streamlined shaped grille blades on 3/4" (19) centers are fixed at 0 or 45 degrees to match and compliment the supply grilles and registers.
2. Optional roll-formed Type 304 stainless steel opposed blade damper has a screw driver operator accessible through face of register.
3. Minimum size is 4" x 4" (102 x 102).  
Maximum size is 60" x 48" (1524 x 1219).
4. Type S Surface mount standard frame has a 1 3/8" (35) face border.
5. Standard fastening is Type A countersunk screw holes.
6. Standard finish is #4 satin polish.

**OPTIONS:**

1. Construction:
  - 316 Type 316 stainless steel.
2. Finish:
  - AW Appliance White.
  - SP Special \_\_\_\_\_.
3.  PFS Stainless Steel Plaster frame
4.  Other \_\_\_\_\_.

**SCHEDULE TYPE:**

**PROJECT:**

**ENGINEER:**

**CONTRACTOR:**

Dimensions are in inches (mm).

DATE	B SERIES	SUPERSEDES	DRAWING NO.
9 - 22 - 11	6700	2 - 1 - 11	6700-3