

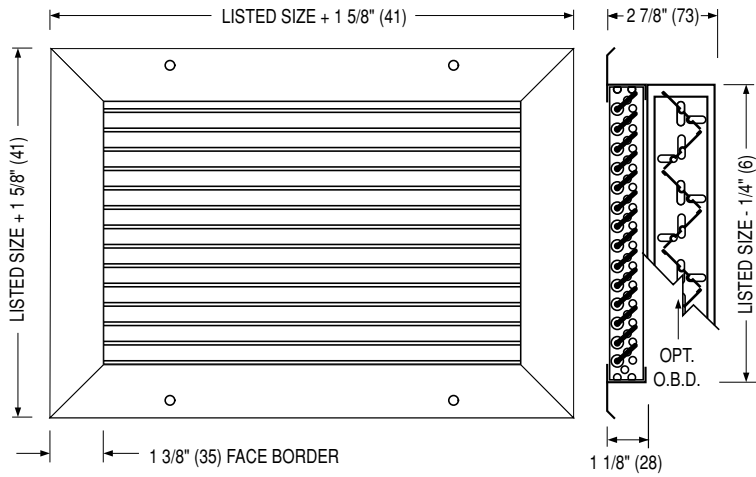

**STAINLESS STEEL RETURN GRILLES & REGISTERS • FIXED BLADE**  
**MODELS: 6755H(-O) AND 6755V(-O) TYPE S**



**MODEL 6755H**  
 Single Deflection Grille  
 Fixed 45° Horizontal Blades

**MODEL 6755H-O**  
 Single Deflection Register  
 Fixed 45° Horizontal Blades  
 (Includes O. B. Damper)

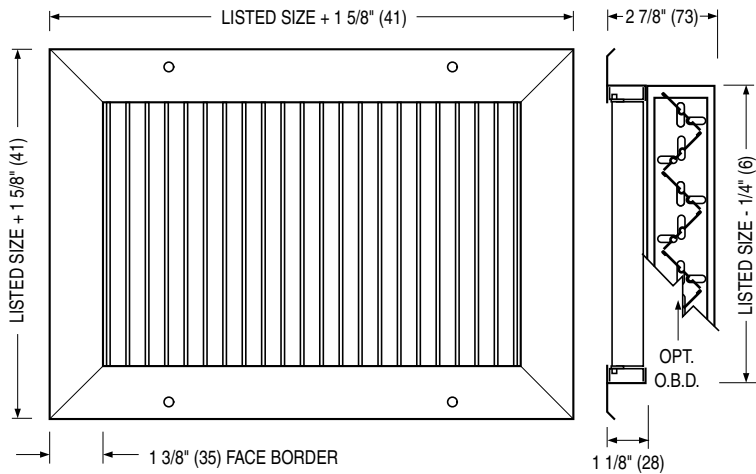

**MODEL 6755V**  
 Single Deflection Grille  
 Fixed 45° Vertical Blades

**6755V-O**  
 Single Deflection Register  
 Fixed 45° Vertical Blades  
 (Includes O. B. Damper)

**DESCRIPTION:**

1. Construction: Type 304 stainless steel welded and reinforced frame features hairline mitered corners. Streamlined shaped grille blades on 1/2" (13) centers are fixed at 45 degrees to match and compliment the supply grilles and registers.
2. Optional roll-formed Type 304 stainless steel opposed blade damper has a screw driver operator accessible through face of register.
3. Minimum size is 4" x 4" (102 x 102).  
Maximum size is 60" x 48" (1524 x 1219).
4. Type S Surface mount standard frame has a 1 3/8" (35) face border.
5. Standard fastening is Type A countersunk screw holes.
6. Standard finish is #4 satin polish.

**OPTIONS:**

1. Construction:
  - 316 Type 316 stainless steel.
2. Finish:
  - AW Appliance White.
  - SP Special \_\_\_\_\_.
3.  PFS Stainless Steel Plaster frame
4.  Other \_\_\_\_\_.

**SCHEDULE TYPE:**

**PROJECT:**

**ENGINEER:**

**CONTRACTOR:**

Dimensions are in inches (mm).

**DATE**

**B SERIES**

**SUPERSEDES**

**DRAWING NO.**

9 - 22 - 11

6700

2 - 1 - 11

6700-4