

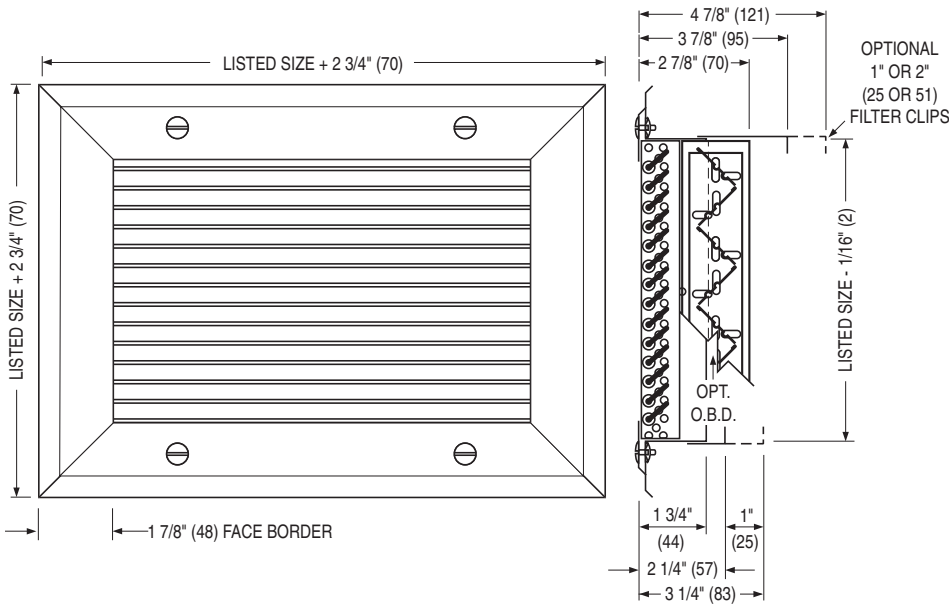

**STAINLESS STEEL RETURN GRILLES
FIXED BLADE
MODELS: 67FB55 AND 67FB55-0**



MODEL 67FB55
Single Deflection Grille
Fixed 45° Horizontal Blades

MODEL 67FB55-0
Single Deflection Register
Fixed 45° Horizontal Blades
(Includes O. B. Damper)

DESCRIPTION:

1. Construction: Type 304 stainless steel welded and reinforced frame features hairline mitered corners. Streamlined shaped grille blades on 1/2" (13) centers are fixed at 45 degrees to match and compliment the supply grilles and registers.
2. Optional roll-formed Type 304 stainless steel opposed blade damper has a screw driver operator accessible through face of register.
3. Minimum size is 4" x 4" (102 x 102).
Maximum size is 60" x 48" (1524 x 1219).
4. Standard frame has a 1 7/8" (48) face border.
5. Standard fastening is Type A countersunk screw holes on the inside neck of the outer frame. Core is secured to the face of the outer frame with stainless steel 1/4 turn fasteners.
6. Standard finish is #3 satin polish.

OPTIONS:

1. Construction:
 - 316 Type 316 stainless steel.
2. Finish:
 - AW Appliance White baked enamel.
 - SP Special _____ .
3. Filter clips:
 - F1 1" (25) (filter by others).
 - F2 2" (51) (filter by others).
4. WT 1/4 Turn 'Wingnut' Fasteners.
5. Other _____ .

SCHEDULE TYPE:

PROJECT:

ENGINEER:

CONTRACTOR:

Dimensions are in inches (mm).

DATE

B SERIES

SUPERSEDES

DRAWING NO.

8 - 29 - 05

6700

7 - 19 - 02

6700-7