

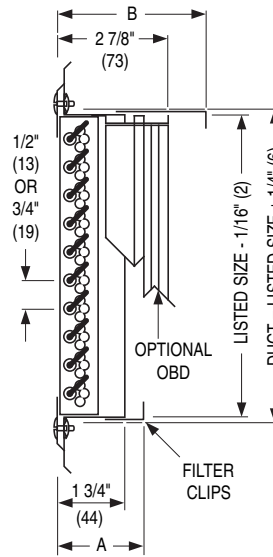

STAINLESS STEEL FILTER RETURN GRILLES
FIXED LOUVERED BLADES • REMOVABLE FACE
MODELS: 67FB45(-O) AND 67FB55(-O)
TYPE S OR L

Frame/Border: Type S Surface Mount

With OBD: B = 3 7/8" (98) for 1" (25) filter. Standard.
 = 4 7/8" (121) for 2" (51) filter. Optional.

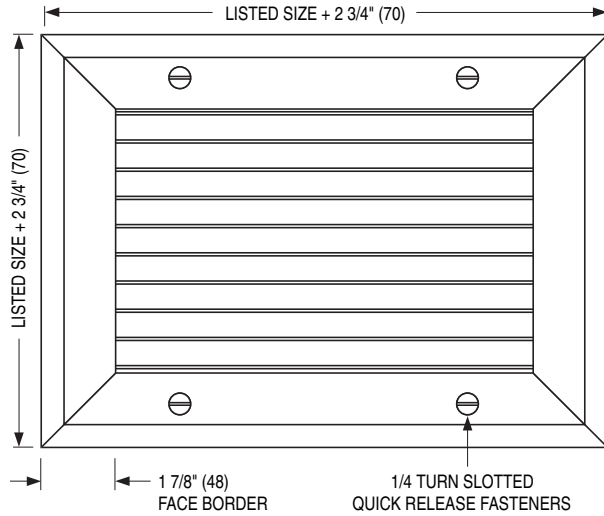

Without OBD: A = 2 1/4" (57) for 1" (25) filter. Standard.
 = 3 1/4" (83) for 2" (51) filter. Optional.

MODEL 67FB45
 45° Deflection Horizontal
 Blades on 3/4" (19) centers

MODEL 67FB45-O
 45° Deflection Horizontal
 Blades on 3/4" (19) centers
 (with O. B. Damper)

MODEL 67FB55
 45° Deflection Horizontal
 Blades on 1/2" (13) centers

MODEL 67FB55-O
 45° Deflection Horizontal
 Blades on 1/2" (13) centers
 (with O. B. Damper)

DESCRIPTION:

1. Construction: Type 304 stainless steel welded and reinforced frame features hairline mitered corners. Streamlined shaped grille blades on 3/4" (19) or 1/2" (13) centers are fixed at 45 degrees to match and compliment the supply grilles and registers.
2. Provision for 1" (25) filter (by others) is standard.
3. Optional roll-formed Type 304 stainless steel opposed blade damper has a screw driver operator accessible through face of register. Opposed blade damper is attached to removable grille.
4. Type S Surface Mount: Minimum size is 4" x 4" (102 x 102). Maximum size is 60" x 48" (1524 x 1219). For Lay-in T-Bar applications, order a listed size that is 3" (76) smaller than ceiling module size.
5. Standard frame has a 1 7/8" (48) face border.
6. Standard fastening is Type A countersunk screw holes on the inside neck of the outer frame. Grille is secured to the face of the outer subframe with Type QT stainless steel 1/4 turn slotted fasteners and is designed to be easily removable for access and cleaning.
7. For cleanroom applications where a quick release removable return grille with mounting frame is required, but a filter is not, the grille may be ordered without filter clips.
8. Standard finish is #4 satin polish.

OPTIONS:

1. Construction:
 - 316 Type 316 stainless steel.
2. Finish:
 - AW Appliance White.
 - SP Special _____ .
3. Filter clips:
 - F2 Provision for 2" (51) filter (by others).
 - FN No filter clips.
4. Core fastening:
 - WT 1/4 turn 'wingnut' fasteners.
 - HTQT Hinged at top with 1/4 turn slotted fasteners on opposite side.
5. Other _____ .

Lay-in sizes (Imperial Ceiling Modules):

Ceiling Module	Listed/Filter Size
12 x 12 (305 x 305)	9 x 9 (229 x 229)
24 x 12 (610 x 305)	21 x 9 (533 x 229)
24 x 24 (610 x 610)	21 x 21 (533 x 533)
36 x 24 (914 x 610)	33 x 21 (838 x 533)
48 x 24 (1219 x 610)	45 x 21 (1143x 533)

SCHEDULE TYPE:

PROJECT:

ENGINEER:

CONTRACTOR:

Dimensions are in inches (mm).

DATE	B SERIES	SUPERSEDES	DRAWING NO.
9 - 22 - 11	6700	2 - 1 - 11	67F-1