

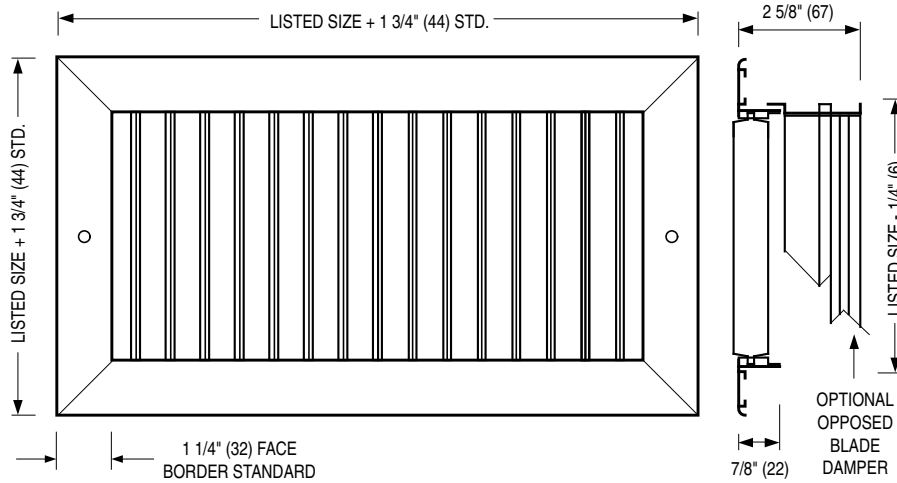

**ALUMINUM AIRFOIL BLADE
SUPPLY GRILLES & REGISTERS
SINGLE DEFLECTION • ADJUSTABLE
MODELS: 71SV(-O) AND 71SH(-O) TYPE S**

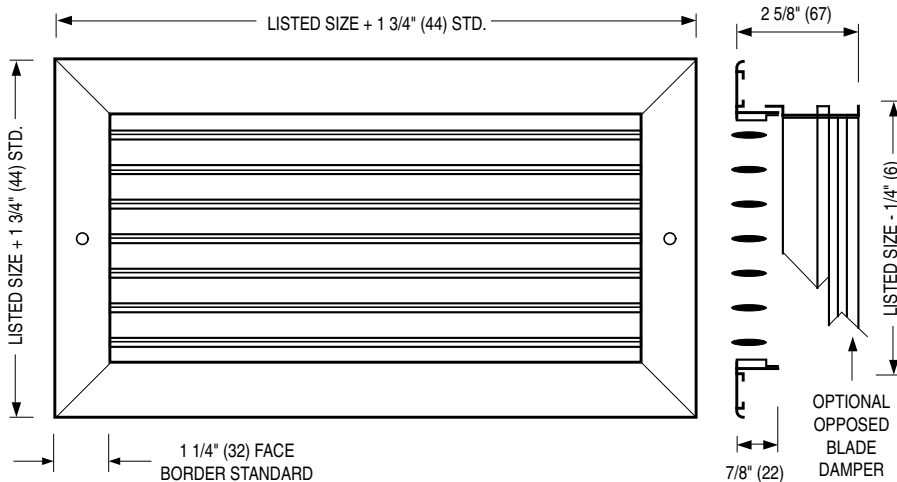

- MODEL 71SV**
Single Deflection Grille
Vertical Blades
- MODEL 71SV-O**
Single Deflection Register
Vertical Blades
(Includes O. B. Damper)



- MODEL 71SH**
Single Deflection Grille
Horizontal Blades
- MODEL 71SH-O**
Single Deflection Register
Horizontal Blades
(Includes O. B. Damper)

DESCRIPTION:

1. Construction: Extruded aluminum. Rigid heavy-gauge frame mechanically interlocked with reinforced mitered corners. A single set of streamlined airfoil shaped solid blades on 3/4" (19) centers provide air control in a single plane. Blades are adjustable and individually pivoted to ensure positive positioning when adjusted to desired deflection setting.
2. Optional roll-formed steel opposed blade damper has a screw driver slot operator accessible through face of register.
3. Minimum size is 4" x 4" (102 x 102). Maximum size is 48" x 48" (1219 x 1219).
4. Type S Surface mount standard frame has 1" (25) overlap margin.
5. Standard fastening is Type A countersunk screw holes.
6. Standard finish is AW Appliance White.

OPTIONS:

1. Finish:
 - SA Satin (clear) anodized
 - SP Special _____ .
2. Fastening:
 - Type C Concealed mounting straps
 - Type D Concealed screw holes in neck
 - Type N None.
3. Type NF Narrow frame with 1" (25) face border and a 3/4" (19) overlap margin. O.A. flange to flange dim. = listed size + 1 1/4" (32).
4. PF Plaster sub-frame
5. IS Insect screen

SCHEDULE TYPE:

PROJECT:

ENGINEER:

CONTRACTOR:

Dimensions are in inches (mm).

DATE	B SERIES	SUPERSEDES	DRAWING NO.
2 - 1 - 11	7100	2 - 25 - 04	7100-1