

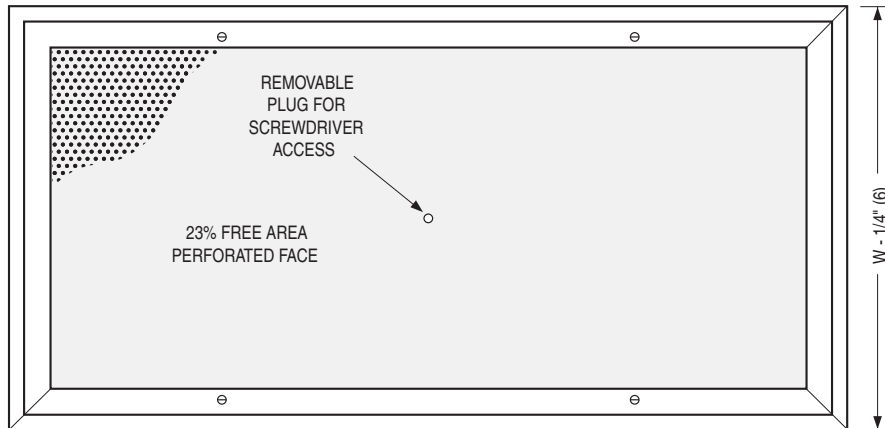

LAMINAR FLOW CEILING DIFFUSER
STAINLESS STEEL • DUAL CHAMBER
CRITICAL ENVIRONMENT APPLICATIONS
MEDIUM CAPACITY DESIGN
MODEL: 92LFDM-SS

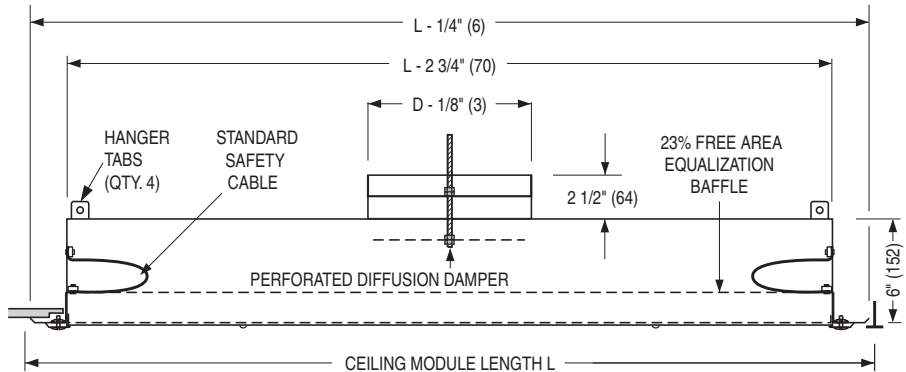

TYPE S Surface Mount Detail

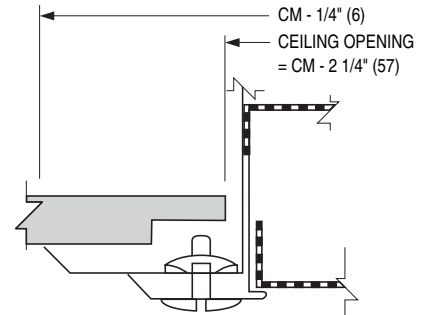

TYPE L* Lay-in T-Bar Detail

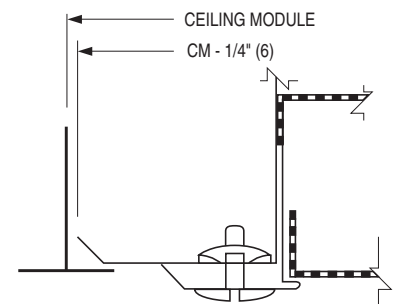

*Compatible with T-Bars up to 1 1/4" (32) wide.

Ceiling Module Sizes L x W & Nominal Round Duct Sizes D

L x W	Imperial Modules (inches)								
	48 x 12	60 x 12	72 x 12	24 x 24	36 x 24	48 x 24	60 x 24	72 x 24	
	Metric Modules (mm)								
	1200 x 300	1500 x 300	1800 x 300	600 x 600	900 x 600	1200 x 600	1500 x 600	1800 x 600	
Duct Size D	(inches)	8	10	10	8, 10, 12	10, 12, 14	10, 12, 14	12, 14, 16	14, 16, 18
	(mm)	203	254	254	203, 254, 305	254, 305, 356	254, 305, 356	305, 356, 406	356, 406, 457

DESCRIPTION:

The Model 92LFDM-SS Laminar Flow Diffuser is a medium capacity/airflow range design and produces a non-aspirating, low velocity vertical air pattern. Recommended face velocity range is 50 – 90 cfm/sq. ft.

Located above the work area they provide a controlled low velocity downward projection "piston" of conditioned supply air. The "dual chamber" design and internal baffles provide improved air distribution across the perforated diffuser face resulting in superior performance.

The only significant amount of room air entrainment occurs at the outer boundary of the laminar flow mass.

Applications include clean rooms such as research laboratories, animal labs, food processing, pharmaceutical labs and computer rooms where localized heavy cooling loads present a problem.

CONSTRUCTION:

- 304 stainless steel frame and perforated face with 3/32" dia. holes on 60 degree 3/16" (4.76) staggered centers (23% free area). The face plate is removable for cleaning and is secured by 1/4 turn fasteners.
- 304 stainless steel fully welded plenum, perforated pressure plate and disk type damper. Damper adjustment through removable face plug.
- Standard safety cables prevent accidental dropping of removable face.
- Standard finish is #4 Satin Polished finish.

OPTIONS:

- 316 316 Stainless Steel construction.
- Finish:
 - AW Appliance White.
 - SP Special _____ .

SCHEDULE TYPE:

PROJECT:

ENGINEER:

CONTRACTOR:

Dimensions are in inches (mm).

DATE	B SERIES	SUPERSEDES	DRAWING NO.
11 - 21 - 11	9200	3 - 30 - 11	92LFDM-SS