

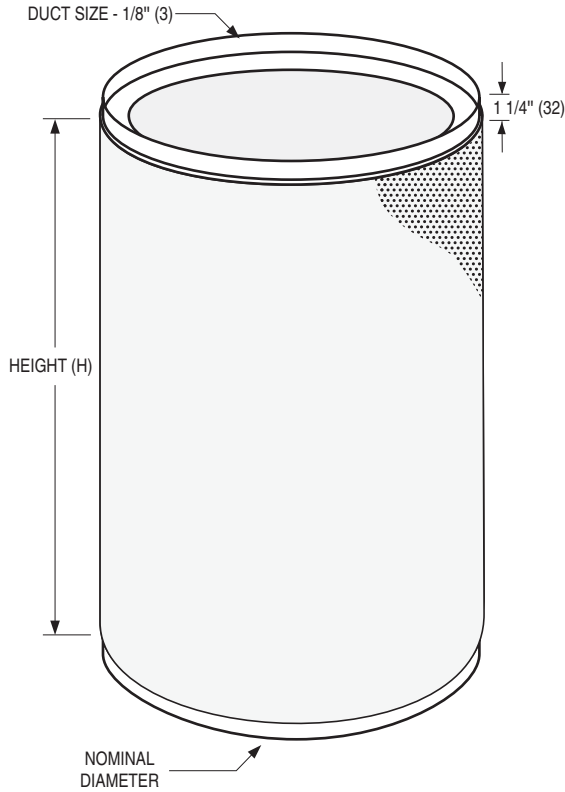

**FULL ROUND 360° DISPLACEMENT DIFFUSER
DUCT HANGING • STEEL PERFORATED FACE
MODEL: DFR360DH**

Model DFR360DH • 360° Radial Discharge Air Pattern



Dimensional Data:

Unit Size (Dia. x H)	Duct Size
12 x 24 (305 x 610)	12 (305)
18 x 24 (457 x 610)	18 (475)
18 x 36 (457 x 914)	
18 x 48 (457 x 1219)	
24 x 24 (610 x 610)	24 (610)
24 x 36 (610 x 914)	
24 x 48 (610 x 1219)	
24 x 60 (610 x 1524)	
30 x 24 (762 x 610)	30 (762)
30 x 36 (762 x 914)	
30 x 48 (762 x 1219)	
30 x 60 (762 x 1524)	

OPTIONS:

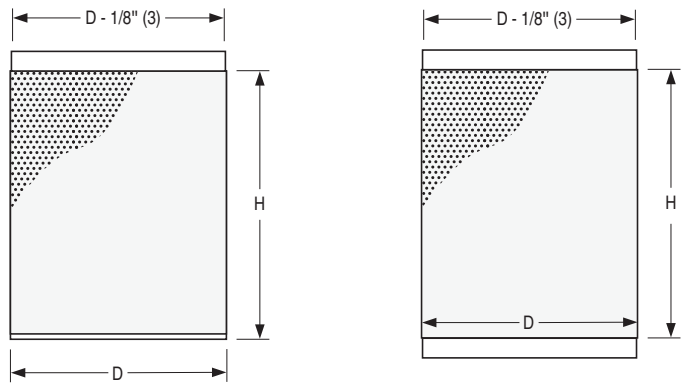

SI SINGLE INLET (STANDARD)

DI DUAL INLET (OPTIONAL)

DESCRIPTION:

1. Construction: Heavy gauge corrosion-resistant coated steel. Standard 18 ga.(1.3) perforated face has 3/32" (2.38) dia. holes on 3/16" (4.76) staggered centers, providing 23% free area.
2. An equalization baffle is provided behind the diffuser face to ensure an even distribution of low velocity supply air.
3. These displacement diffusers are especially designed to supply air at a very low velocity to minimize the potential for drafts and enhance occupant comfort.
The DFR360DH is a special application version of the DFR360 as it is designed to be installed off the floor, either in or above the occupied space. The cool air falls to the floor where it spreads horizontally.
4. Standard finish is AW Appliance White polyester powder coat.

OPTIONS:

1. 14GP Heavy Duty 14 ga. (2.0) perforated face
2. Duct Hanging
 SI Single Inlet (standard)
 DI Dual Inlet
3. Finish
 AL Aluminum
 SP Special _____
4. FMSD Flow Measuring Station with balancing damper (18" [475] is maximum size).
5. Other _____

SCHEDULE TYPE:

PROJECT:

ENGINEER:

CONTRACTOR:

Dimensions are in inches (mm).

DATE	B SERIES	SUPERSEDES	DRAWING NO.
2 - 28 - 11	DFR	NEW	DFR360DH