

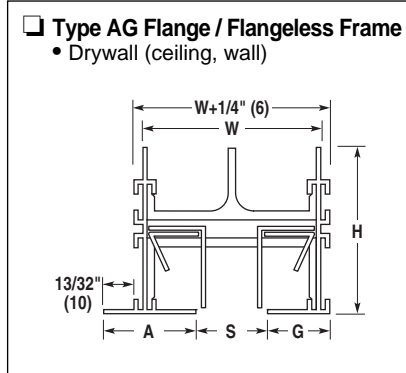

FLOWLINE™ LINEAR SLOT DIFFUSERS
ARCHITECTURAL • ALUMINUM
VERTICAL JET THROW PATTERN CONTROLLERS
MODEL SERIES: FLV TYPES GG & AG

One Slot

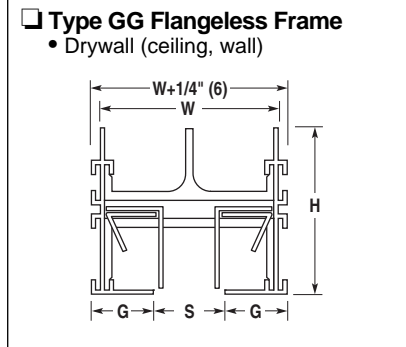

Two Slot

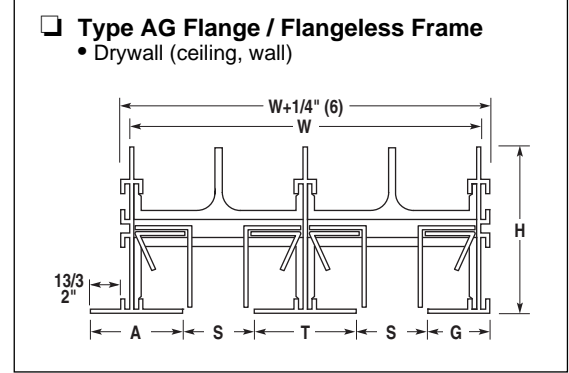
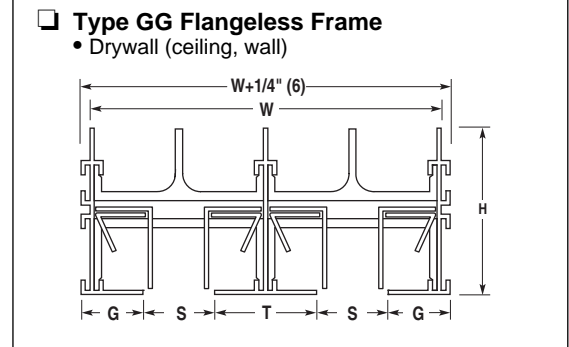

End Condition

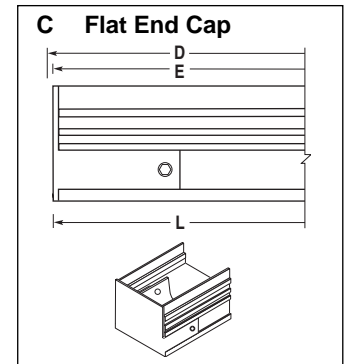
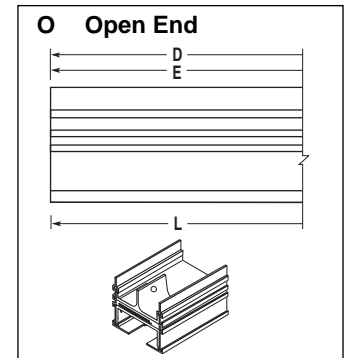
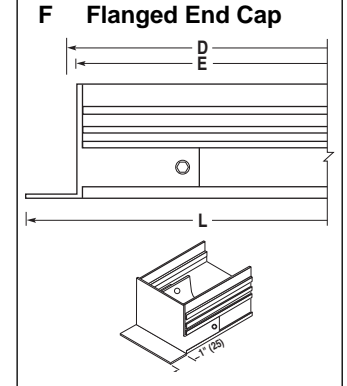

Dimensional Data - Imperial (Metric) Units

Model	S Slot Width	1 Slot W	2 Slot W	A Border Width	G Border Width	H Height	T 2 Slot
FLV10	1 (25)	2 1/2 (64)	4 15/16 (125)	1 9/32 (33)	7/8 (22)	2 3/8 (60)	1 1/16 (37)
FLV15	1 1/2 (38)	3 1/2 (89)	6 15/16 (176)	1 17/32 (39)	1 1/8 (29)	2 5/8 (67)	1 15/16 (49)
FLV20	2 (51)	4 1/2 (114)	8 15/16 (227)	1 25/32 (45)	1 3/8 (35)	2 7/8 (73)	2 7/16 (62)
FLV25	2 1/2 (64)	5 1/2 (140)	10 15/16 (278)	2 1/32 (52)	1 5/8 (41)	3 1/8 (74)	2 15/16 (75)
FLV30	3 (76)	6 1/2 (165)	12 15/16 (329)	2 9/32 (58)	1 7/8 (48)	3 3/8 (86)	3 7/16 (87)

Notes:

1. Material: Heavy duty extruded aluminum frame and spacers. Corrosion resistant steel pattern controllers.
2. Maximum single section length is 144" (3658). Longer lengths are furnished in multiple sections with alignment strips, the number and size determined by the factory.
3. Adjustable pattern controllers are on 24" (610) centers.
4. Standard finish is AW Appliance White baked enamel on exposed frames with black pattern controllers and interior surfaces.
5. Integral hanger brackets on 24" (610) centers. See separate submittal for optional mounting hardware and accessories.

Overall Length and End Cap Position

	E	L
<input type="checkbox"/> OO	D	D
<input type="checkbox"/> OC	D - 1/16 (2)	D - 1/16 (2)
<input type="checkbox"/> CC	D - 1/8 (3)	D - 1/8 (3)
<input type="checkbox"/> FF	D - 1/4 (6)	D + 1 5/8 (41)
<input type="checkbox"/> FO	D - 1/8 (3)	D + 13/16 (21)
<input type="checkbox"/> FC	D - 1/16 (2)	D + 7/8 (22)

Options:

SP Special Finish _____.

SCHEDULE TYPE		Dimensions are in inches (mm).			
PROJECT					
ENGINEER	DATE	B SERIES	SUPERSEDES	DRAWING NO.	
CONTRACTOR	2 - 16 - 10	FL	10 - 18 - 07	FLV-3	