



FORMED STEEL LOUVER

4" (102) DEEP • STANDARD BLADE (J-STYLE)

MODEL: 1704SB

Model 1704SB, standard blade type (J-style), is an architecturally styled 4" (102) deep formed louver designed with smooth, clean lines that visually compliment any structure's exterior styling. Galvanized steel construction is economical, yet durable and is available with channel or flanged frame. The drainable head feature utilizes a top gutter that collects the water running down the building face and channels it out the concealed downspouts in the side frame, thus preventing it from flowing down into the airstream. Suitable for use in exhaust and low to medium velocity intake applications, the blade design features a rear water baffle and provides good protection against general weather conditions, with low pressure drop characteristics and a high free area. Model 1704SB is AMCA Licensed and is engineered to be architecturally appealing as well as mechanically enduring.

STANDARD CONSTRUCTION:

- FRAME:** 4" (102) deep, 18 ga. (1.3) formed galvanized steel.
- BLADES:** 20 ga. (1.0) formed galvanized steel (J-Style).
- BLADE ANGLE:** Fixed at 45 degrees.
- BLADE SPACING:** Approx. 4" (102) on centers.
- BLADE SUPPORT BRACKETS:** Concealed type, factory installed on rear of louver on maximum 48" (1219) centers. Reinforced with 1" x 1" (25 x 25) angle (adds approx. 1" (25) to overall louver depth).
- MULLIONS:** Visible type. See Note #1.
- SCREEN:** 1/2" x 1/2" x 19 ga. (13 x 13 x 1.0) galvanized bird screen.
- FINISH:** Mill.
- MINIMUM SIZE:** 12" wide x 12" high (305 x 305).
- MAXIMUM SECTION SIZE:** 60" wide x 96" high (1524 x 2438).

OPTIONS:

- FL** Flanged Frame.
- BSA** Aluminum Bird Screen.
- ISA** Aluminum Insect Screen.

OPTIONAL FINISHES:

- BE** Baked Enamel. Color: _____.
- KY** Kynar 500®/Hylar 5000®. Color: _____.
- PCF** Prime Coat.

NOTES:

1. Sizes larger than maximum section size will be manufactured in multiple equal size panels with visible mullion frames for assembly in the field. Installation of multiple panels may require structural reinforcing (not by Nailor) to provide sufficient support. Standard individual sections are designed to withstand a 25 p.s.f. wind load (100 mph). Contact Nailor for higher wind loads. For additional installation information, see AMCA Publication 501 (Application Manual for Air Louvers).
2. Bird screen adds 3/8" (10) to louver depth.
3. All mounting hardware, clip angles, etc. by others.

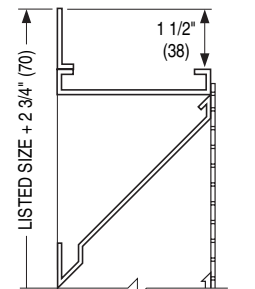
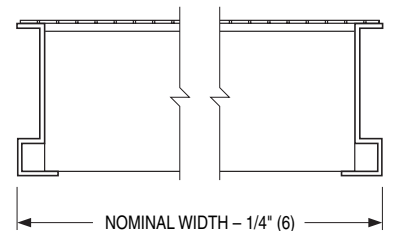
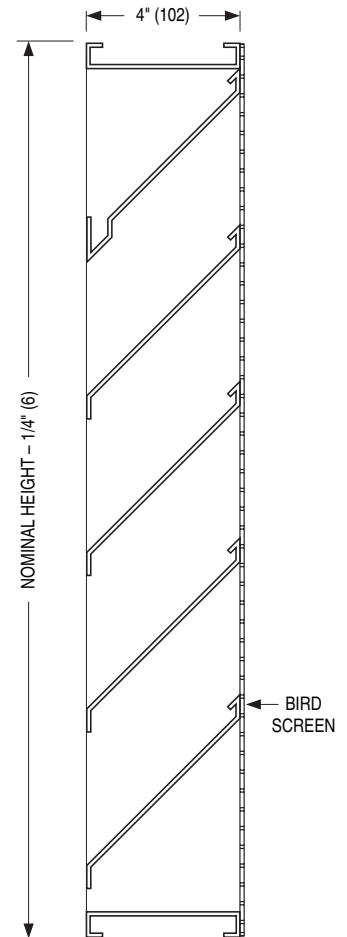

OPTIONAL FLANGED FRAME (FL)

Dimensions are in inches (mm).

SCHEDULE TYPE:
PROJECT:
ENGINEER:
CONTRACTOR:

DATE	B SERIES	SUPERSEDES	DRAWING NO.
6 - 3 - 09	1700	4 - 2 - 09	1704SB-1



FORMED STEEL LOUVER
4" (102) DEEP • STANDARD BLADE (J-STYLE)
PERFORMANCE DATA
MODEL: 1704SB

FREE AREA in Square Feet and Square Meters

		Width in Inches and Meters								
		12	18	24	30	36	42	48	54	60
Height in Inches and Meters	12	0.26	0.40	0.55	0.69	0.84	0.99	1.13	1.28	1.43
	0.30	0.02	0.04	0.05	0.06	0.08	0.09	0.11	0.12	0.13
	18	0.54	0.85	1.16	1.46	1.77	2.08	2.39	2.70	3.01
	0.46	0.05	0.08	0.11	0.14	0.16	0.19	0.22	0.25	0.28
	24	0.80	1.25	1.71	2.16	2.62	3.08	3.53	3.99	4.44
	0.61	0.07	0.12	0.16	0.20	0.24	0.29	0.33	0.37	0.41
	30	1.08	1.70	2.32	2.93	3.55	4.17	4.79	5.40	6.02
	0.76	0.10	0.16	0.22	0.27	0.33	0.39	0.44	0.50	0.56
	36	1.36	2.14	2.92	3.70	4.48	5.26	6.04	6.82	7.60
	0.91	0.13	0.20	0.27	0.34	0.42	0.49	0.56	0.63	0.71
	42	1.62	2.55	3.48	4.40	5.33	6.26	7.18	8.11	9.04
	1.07	0.15	0.24	0.32	0.41	0.50	0.58	0.67	0.75	0.84
	48	1.91	2.99	4.08	5.17	6.26	7.35	8.29	9.53	10.62
	1.22	0.18	0.28	0.38	0.48	0.58	0.68	0.77	0.89	0.99
	54	2.16	3.40	4.64	5.87	7.11	8.35	9.58	10.82	12.05
	1.37	0.20	0.32	0.43	0.55	0.66	0.78	0.89	1.01	1.12
60	2.45	3.85	5.24	6.64	8.04	9.44	10.84	12.24	13.63	
1.52	0.23	0.36	0.49	0.62	0.75	0.88	1.01	1.14	1.27	
66	2.71	4.25	5.80	7.34	8.89	10.43	11.98	13.53	15.07	
1.68	0.25	0.39	0.54	0.68	0.83	0.97	1.11	1.26	1.40	
72	2.99	4.70	6.40	8.11	9.82	11.53	13.24	14.94	16.65	
1.83	0.28	0.44	0.59	0.75	0.91	1.07	1.23	1.39	1.55	
78	3.27	5.14	7.01	8.88	10.75	12.62	14.49	16.36	18.23	
1.98	0.30	0.48	0.65	0.83	1.00	1.17	1.35	1.52	1.69	
84	3.53	5.55	7.56	9.58	11.60	13.62	15.63	17.65	19.67	
2.13	0.33	0.52	0.70	0.89	1.08	1.26	1.45	1.64	1.83	
90	3.81	5.99	8.17	10.35	12.53	14.71	16.89	19.07	21.25	
2.29	0.35	0.56	0.76	0.96	1.16	1.37	1.57	1.77	1.97	
96	4.07	6.40	8.72	11.05	13.38	15.70	18.03	20.36	22.68	
2.44	0.38	0.59	0.81	1.03	1.24	1.46	1.68	1.89	2.11	

AIRFLOW/ WATER PENETRATION DATA
for 48" x 48" (1219 x 1219) Louver Size

Free Area %	52%
Free Area sq. ft. (sq. m.)	8.29 (0.77)
Free Area Velocity at Point of Beginning Water Penetration at .01 oz./sq. ft. (3 ml/sq. m) (15 min. test duration)	937 fpm (286 m/min.)
Air Volume at 937 fpm	7768 cfm (3666 l/s)
Free Area Velocity	
Pressure Drop @ 937 fpm	.16 in. w.g. (40 Pa)

NOTE: To minimize water penetration when sizing intake louvers, select a Free Area Velocity that is **below** the point of beginning water penetration.



Nailor Industries Inc. certifies the Model 1704SB shown herein is licensed to bear the AMCA Seal. The ratings shown are based on tests and procedures performed in accordance with AMCA Publication 511 and comply with the requirements of the AMCA Certified Ratings Program. Seal applies to air performance ratings and water penetration ratings.

PRESSURE DROP

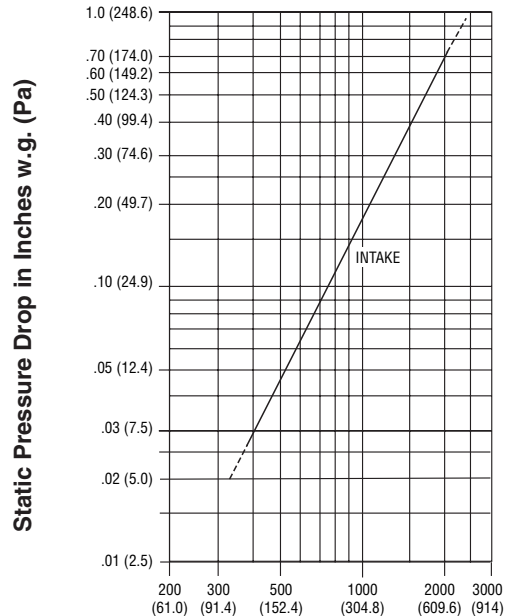

Air Velocity in Feet (Meters) Per Minute Through Free Area
 Louver test size: 48" x 48" (1219 x 1219 mm). Standard air density @ 0.075 lbs/ft³.
 Tested to AMCA Fig. 5.5-6.5.

SCHEDULE TYPE:

PROJECT:

Dimensions are in inches (mm).

ENGINEER:

DATE

B SERIES

SUPERSEDES

DRAWING NO.

CONTRACTOR:

6 - 3 - 09

1700

4 - 2 - 09

1704SB-2