



UNDERFLOOR FAN BOOSTER UNIT WITH ECM MOTOR • COOLING AND HEATING DAMPERS • VARIABLE OR CONSTANT VOLUME MODELS: 38F, 38FW AND 38FE • UNIT SIZE 33

STANDARD FEATURES:

- 20 ga. (1.0) galvanized steel casing components.
- Dual fan operation on cooling.
- Single fan operation on heating. Backdraft damper on slave cooling unit inlet prevents back flow during heating.
- Unit incorporates two low leakage dampers for 2 position open/closed operation. One is used for supply air cooling mode airflow (from underfloor plenum along with slave) and the other for return air heating mode airflow (ducted).
- Full size top access panel.
- Access door for side access to damper actuators.
- Return heating inlet and discharge openings designed for flanged duct connection.
- 1/2" (13) dual density insulation, exposed edges coated to prevent air erosion. Meets requirements to NFPA 90A and UL181.
- Ultra-high efficiency ECM fan motor. EPIC fan volume controller.
- Motor blower assembly mounted on special 16 ga. (1.6) angles and isolated from casing with rubber isolators.
- Single point electrical connection.
- Top access hinged door on the line voltage/fan controls enclosure.
- Controls are mounted in optional position on LH side as shown. (Controls are mounted as standard on RH side. See submittal drawing 38F-33DRH).

OPTIONS:

- Toggle disconnect switch.
- Fiber-free liner.
- Perforated metal liner.
- Steri-liner.
- Solid metal liner.
- Rubber support feet.
- Fan Unit fusing.
- Heating Damper Collar. Flat oval transition collar on return inlet for flexible duct connection (back or side location). 10" (11 1/8" x 7 3/4") or 12" (14 1/4" x 7 3/4").
- Discharge collars. Flat oval transitions for flexible duct connection. 12" (14 1/4" x 7 3/4").
- Special features: _____.

Model 38F Basic Unit

LEFT HAND DESIGN LAYOUT

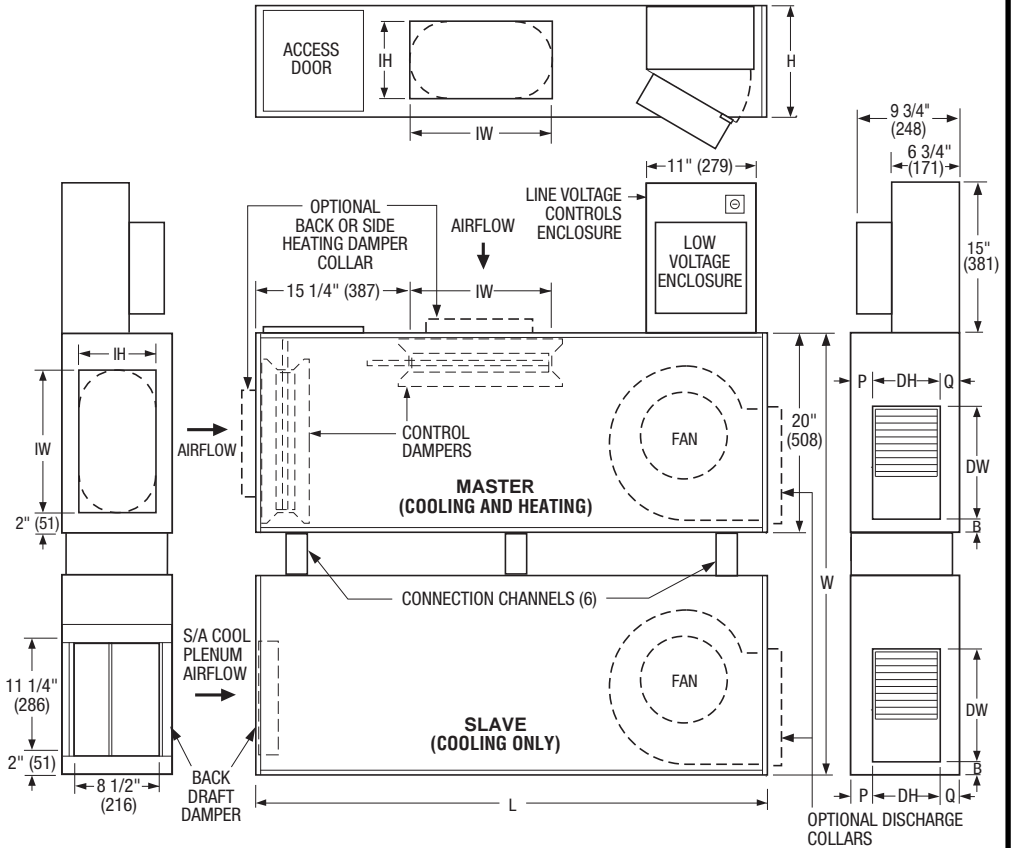

Dimensional Data. Imperial Units (inches)

Unit Size	W	H	L	B	P	Q	Inlets IW x IH	Outlet Discharge DW x DH
33	44 1/2	11	50 7/8	1 3/8	2	2	14 1/4 x 7 3/4	11 1/4 x 7

Dimensional Data. Metric Units (mm)

Unit Size	W	H	L	B	P	Q	Inlet IW x IH	Outlet Discharge DW x DH
33	1130	279	1292	35	51	51	330 x 229	286 x 178

Electrical Data

Unit Size	Motor H.P.	ECM Motor			
		Voltage	120/1/60	208/240/1/60	277/1/60
33	2@1/3	Watts	840	900	820
		FLA	11.6	6.81	5.8

FLA = Full load amperage



SCHEDULE TYPE:

PROJECT:

ENGINEER:

CONTRACTOR:

Page 1 of 3
Dimensions are in inches (mm).

DATE	B SERIES	SUPERSEDES	DRAWING NO.
8 - 20 - 08	38F	8 - 13 - 07	38F-33DLH



**UNDERFLOOR FAN BOOSTER UNIT WITH
ECM MOTOR • COOLING & HEATING DAMPERS
VARIABLE OR CONSTANT VOLUME • HOT WATER HEAT
MODEL: 38FW • UNIT SIZE 33**

**Hot Water Coil Section
Model 38FW**

Standard Features:

- Coil section installed on master unit discharge.
- Coil (and header on multi-circuit units) is installed in insulated casing for increased thermal efficiency.
- 1/2" (13) copper tubes.
- Aluminum ripper fins.
- Sweat connections: One Row 1/2" (13) O.D. male solder. Two and three row 7/8" (22) O.D. male solder.
- Full size top access panels for inspection and coil cleaning.
- Flanged outlet duct connection.

Coil Rows:

- 1-Row 2-Row 3-Row

Coil Connections:

(Looking in direction of airflow).
Left hand (illustrated). Optional.
(Terminal ordered with RH coil connections as standard. See submittal drawing 38F-33DRH)

Options:

- Discharge collars. Flat oval transitions for flexible duct connection. 12" (14 1/4" x 7 3/4").
- Special features: _____.

LEFT HAND DESIGN LAYOUT

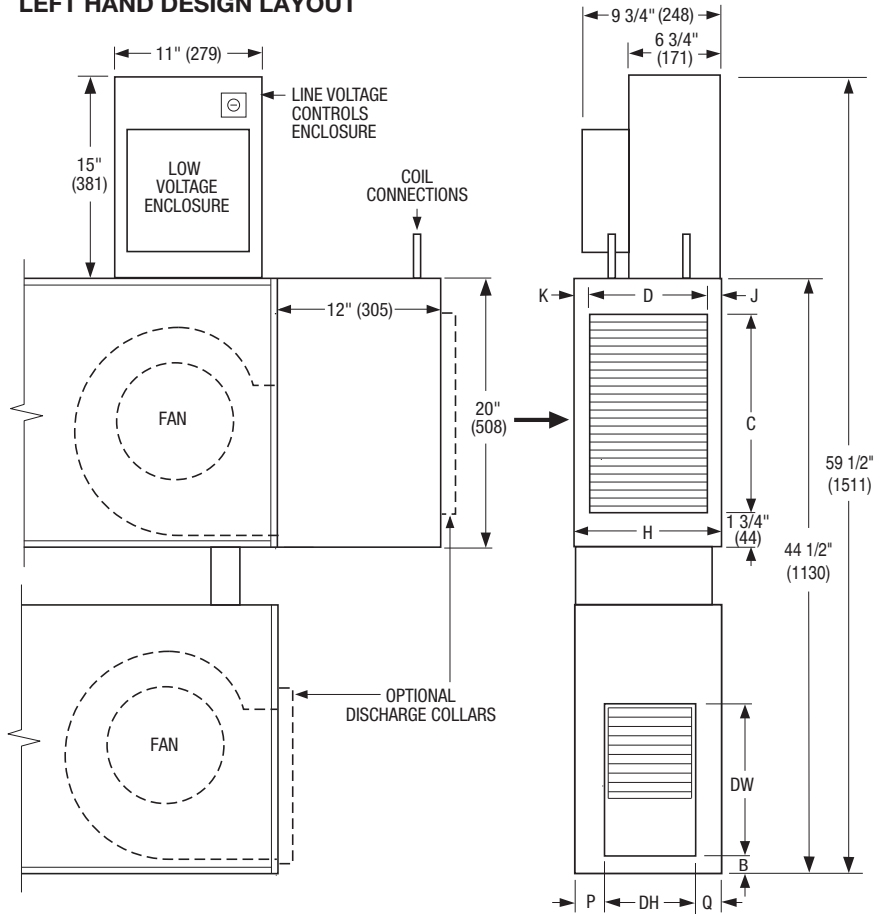

Dimensional Data. Imperial Units (inches)

Unit Size	H	B	P	Q	J	K	Outlet Discharge C x D	Outlet Discharge DW x DH
33	11	1 3/8	2	2	1	1 3/4	14 3/4 x 8 3/4	11 1/4 x 7

Dimensional Data. Metric Units (mm)

Unit Size	H	B	P	Q	J	K	Outlet Discharge C x D	Outlet Discharge DW x DH
33	279	35	51	51	29	29	375 x 222	286 x 178



SCHEDULE TYPE:				
PROJECT:				
ENGINEER:	DATE	B SERIES	SUPERSEDES	DRAWING NO.
CONTRACTOR:	8 - 20 - 08	38F	8 - 13 - 07	38F-33DLH



**UNDERFLOOR FAN BOOSTER UNIT WITH
ECM MOTOR • COOLING & HEATING DAMPERS
VARIABLE OR CONSTANT VOLUME • ELECTRIC HEAT
MODEL: 38FE • UNIT SIZE 33**

**Electric Coil Section
Model 38FE**

Standard Features:

- Coil installed on master unit discharge.
- Insulated heater element wrapper.
- Automatic reset high limit cut-outs (one per element).
- Flanged outlet duct connection.
- Airflow safety switch to prove airflow.
- Single Point electrical connection for entire terminal unit.
- Terminal unit with heater is ETL listed as an assembly.
- Controls mounted in optional position on LH side as shown (Terminal ordered with RH controls are standard. See submittals 38F-33DRH).

Voltage:

Single phase, 60 Hz.

- 208V 240V 277V

Three phase, 60 Hz.

- 208V 480V (4 wire wye).

Options:

- Toggle disconnect switch.
- Door interlock disconnect switch.
- Mercury contactors.
- Power circuit fusing.
- Class 'A' 80/20 Ni./Cr. Wire.
- Dust tight construction.
- Manual reset secondary thermal cut out.
- Discharge collars. Flat oval transitions for flexible duct connection. 12" (14 1/4" x 7 3/4").
- Special features: _____

LEFT HAND DESIGN LAYOUT

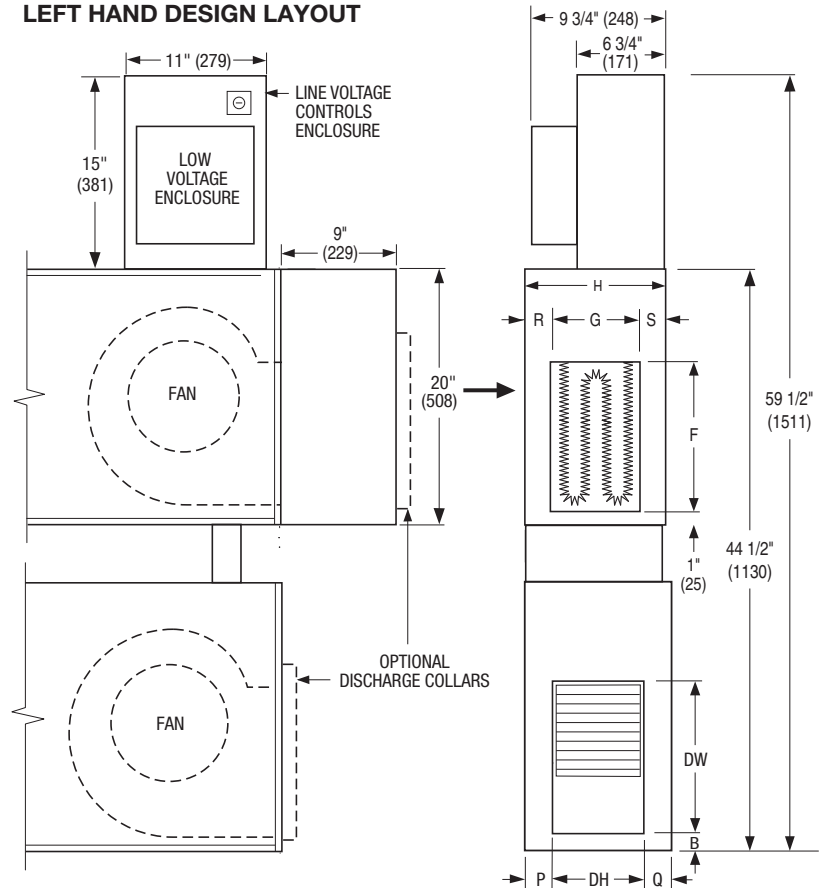

Dimensional Data. Imperial Units (inches)

Unit Size	H	B	P	Q	R	S	Outlet Discharge F x G	Outlet Discharge DW x DH
33	11	1 3/8	2	2	1 5/8	1 5/8	11 x 7 3/4	11 1/4 x 7

Dimensional Data. Metric Units (mm)

Unit Size	H	B	P	Q	R	S	Outlet Discharge F x G	Outlet Discharge DW x DH
33	279	35	51	51	41	41	279 x 197	286 x 178



SCHEDULE TYPE:			
PROJECT:			
ENGINEER:	DATE	B SERIES	SUPERSEDES
CONTRACTOR:	8 - 20 - 08	38F	8 - 17 - 07
		DRAWING NO.	38F-33DLH