

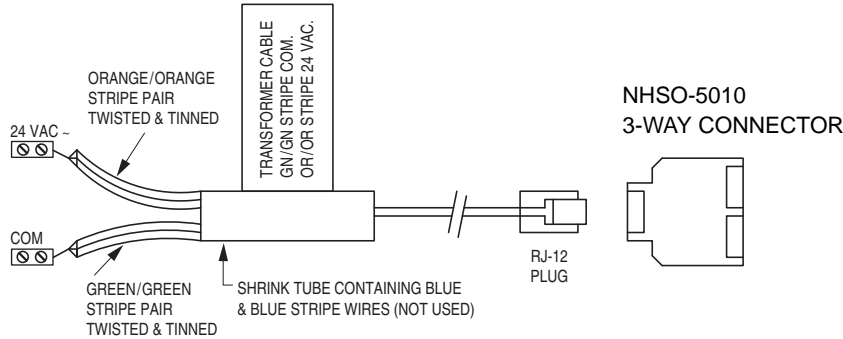

VAV FLOOR DIFFUSER COMMUNICATION CABLES UNDERFLOOR AIR DISTRIBUTION SYSTEMS MODEL SERIES: NHSO

NAILOR NPS POWER SUPPLY MODULE: NHSO-5011 (12") TRANSFORMER CABLE



CABLE SPECIFICATION:
24 AWG 6-Conductor Plenum Cable
UL Type: MPP / CMP
CUL PCC FT6-Level 2 or higher

ACTUATOR CABLES:

NHSO-5013-12 (12 ft.) Standard
NHSO-5013-20 (20 ft.) Optional
NHSO-5013-50 (50 ft.) Optional
Connects VAV diffusers to each other and/or power supply module.

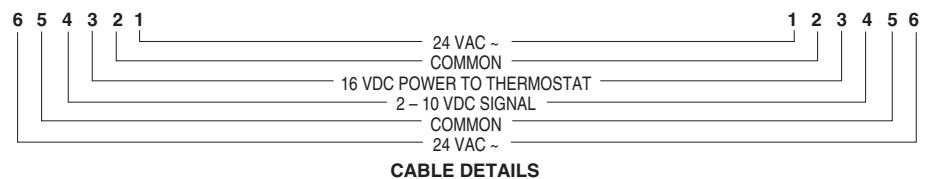
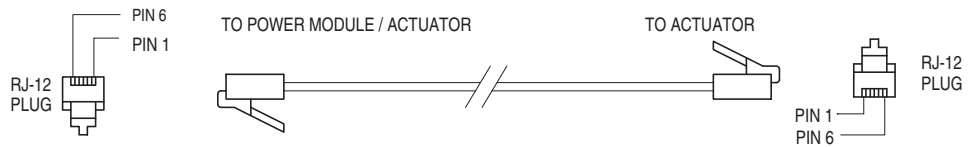

THERMOSTAT/BAS CABLE:

NSHO-5012 (50 ft.) CONNECTS TO A VAV DIFFUSER AT END OF DAISY CHAIN

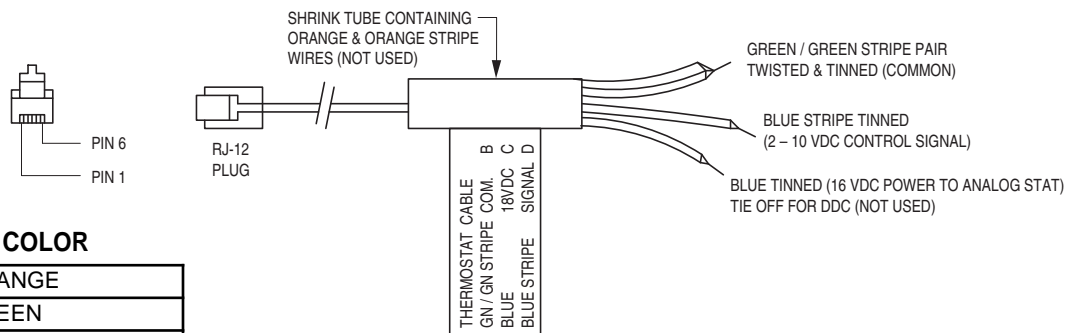

WIRING TABLE COLOR

PIN 1	ORANGE
PIN 2	GREEN
PIN 3	BLUE
PIN 4	BLUE STRIPE
PIN 5	GREEN STRIPE
PIN 6	ORANGE STRIPE

SCHEDULE TYPE:

PROJECT:

ENGINEER:

CONTRACTOR:

Dimensions are in inches (mm).

DATE

B SERIES

SUPERSEDES

DRAWING NO.

9 - 22 - 09

NLD

11 - 12 - 07

NHSO-1