



VAV LINEAR FLOOR DIFFUSERS WITH ACTUATOR
UNDERFLOOR AIR DISTRIBUTION SYSTEMS
VAV • HEATING WITH DUCTED COOLING
MODEL: NLD-VHCD

DESCRIPTION:

The Nailor NLD Linear Floor Diffusers are designed for use in raised access floor air distribution systems. High quality, heavy duty, extruded aluminum linear grilles are featured providing an architecturally appealing face design that compliments contemporary decor. Heavy gauge steel plenums incorporate a large dust/dirt collection area that catches anything that might fall through the diffuser face.

Model NLD-VHCD provides variable air volume heating only control (from pressurized floor plenum) with constant volume (ducted) cooling. A 90° rotation (CW to open) low leakage damper and integral modulating actuator provide precise airflow control during the heating cycle.

FEATURES:

- Meets all the requirements of NFPA 90A.
- Complete assembly including actuator is UL tested and classified in accordance with UL standard 2043.
- Simple installation, unit fits into place from the top (room side) of the floor panel.
- 12" (305) overall height allows installation in 12" (305) raised access floors.
- Five available heavy duty core styles to choose from (see following page).
- All heavy duty cores are removable and supplied with core clips as standard.
- Two available frame options (Frame F or H).
- Standard fastening is Type B friction spring clips.
- Compact 24 VAC direct drive proportional actuator c/w cover.
- Minimum and maximum airflow limits are achieved by limiting the range of the control signal.
- Actuator features two RJ12 ports for simple interconnection using modular plenum rated cables. Multiple units can be 'daisy-chained' together.
- Optional thermostat, thermostat cable and power supply modules are available (see following pages).
- Optional Type DV directional vanes provide an adjustable discharge pattern to enhance coverage of perimeter windows and reduce throw.
- Optional BKP black painted finish on interior plenum surfaces.
- Optional BDD backdraft damper is available on the ducted inlet.
- Standard finish is AW Appliance White.



NAILOR INDUSTRIES INC.
FLOOR DIFFUSER
 AS TO HEAT RELEASE RATE AND SMOKE OPTICAL DENSITY ONLY
R21545 25KU

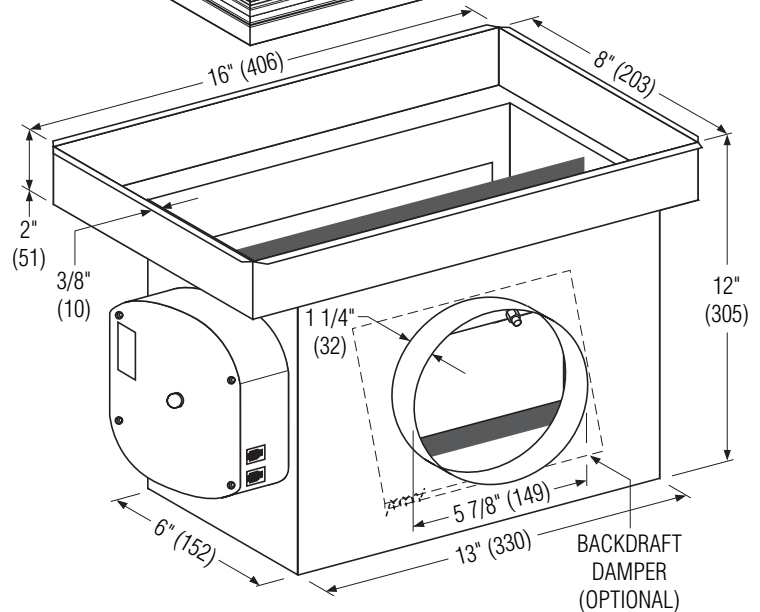
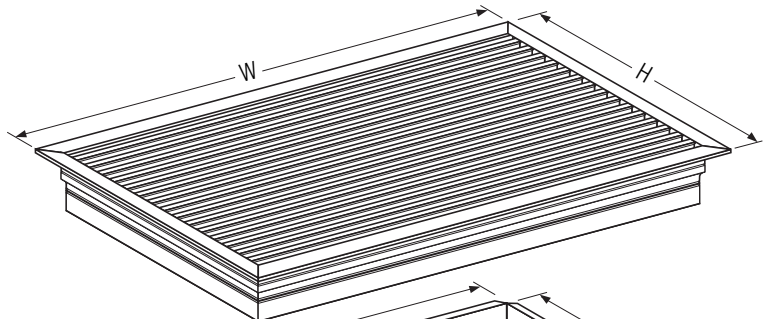

FLOOR OPENING = 16 1/4" x 8 1/4" (413 x 210)
 W = 17 5/8" (448) FOR FRAME F OR 17 1/8" (435) FOR FRAME H
 H = 9 5/8" (244) FOR FRAME F OR 9 1/8" (232) FOR FRAME H

SCHEDULE TYPE:	
PROJECT:	
ENGINEER:	
CONTRACTOR:	

Page 1 of 3
 Dimensions are in inches (mm).

DATE	B SERIES	SUPERSEDES	DRAWING NO.
2 - 12 - 07	NLD	8 - 30 - 05	NLD-VHCD

1. CORE SELECTION:

- 480 - 1/8" (3) Bars - 1/4" (6) Spacing - 0° Deflection (Standard)

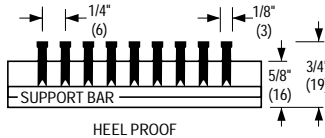

- 481 - 1/8" (3) Bars - 1/4" (6) Spacing - 15° Deflection

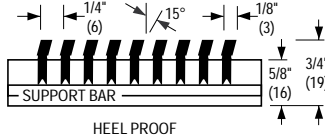

- 240 - 1/4" (6) Bars - 1/2" (13) Spacing - 0° Deflection

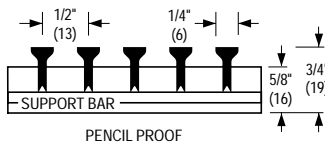

- 241 - 1/4" (6) Bars - 1/2" (13) Spacing - 15° Deflection

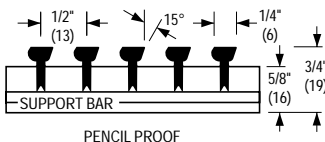

- 243 - 1/4" (6) Bars - 1/2" (13) Spacing - 30° Deflection

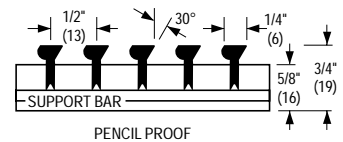

2. FRAME SELECTION:

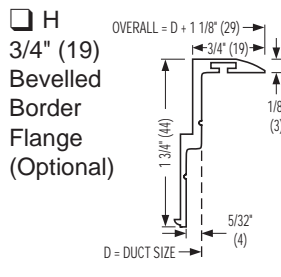
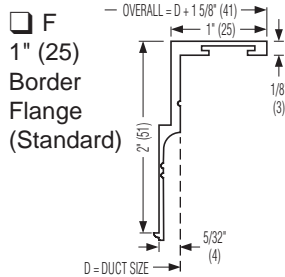

3. FASTENING SELECTION:

- TYPE B**
Spring Clip (Frames F or H) (Standard)

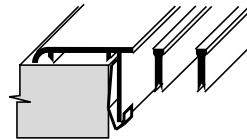

- TYPE A**
#8 Countersunk Screw Holes. (Frame F only) (Optional)

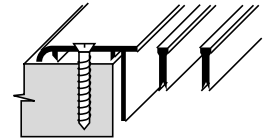

4. ACTUATOR CABLE SELECTION:

- 12 12 ft. long (Standard)
- 20 20 ft. long

5. FINISH SELECTION:

- AW Appliance White (Standard)
- GRT Gray (textured)
- BKT Black (textured)
- AL Aluminum
- SA Satin (clear) Anodized
- BC Brushed clear-coat lacquer
- MI Mill
- BK Black
- SP Special _____
- SPT Special (textured) _____

6. OPTIONS:

- DV** Directional Vanes
Fully adjustable extruded aluminum blades on 3/4" (19) centers perpendicular to length.

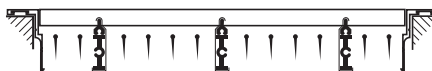

- BKP** Plenum interior painted black.
- BDD** Backdraft Damper (on ducted inlet)

SCHEDULE TYPE:

PROJECT:

ENGINEER:

CONTRACTOR:

Page 2 of 3
 Dimensions are in inches (mm).

DATE

B SERIES

SUPERSEDES

DRAWING NO.

2 - 12 - 07

NLD

8 - 30 - 05

NLD-VHCD



VAV LINEAR FLOOR DIFFUSERS WITH ACTUATOR

UNDERFLOOR AIR DISTRIBUTION SYSTEMS

VAV • HEATING WITH DUCTED COOLING

MODEL: NLD-VHCD

DESCRIPTION:

The Nailor NLD floor diffuser is designed to provide VAV control in cooling applications. Advanced micro-computer electronics and P+I control algorithms provide precise temperature control.

CONTROL FEATURES:

- Fast connection/wiring between units with RJ12 (phone jack) connections. Allows units to be quickly installed or relocated.
- Compact direct-drive 24 VAC actuator utilizes a 2 – 10 VDC control signal for precise airflow control.
- Standard 12 ft. modular plenum rated cables, for interconnection between diffusers, allows diffusers to be spaced on 10 ft. intervals (20 ft. cables optional).
- Power supply modules allow connection of up to 12 units on each line voltage connection (6 diffusers on each side) (8 units total or 4 on each side with optional 20 ft. cables).
- Each thermostat can control a maximum of 3 power supplies.
- Minimum and maximum airflow limits are adjusted underneath the thermostat cover.

ACCESSORIES:

1. Thermostat
 - NCTE-5015-10 °F Scale
 - NCTE-5015-11 °C Scale
2. Cables:
 - NHSO-5012 50 ft. Thermostat Cable
3. Power Supply Module (includes NHSO-5011 transformer cable, NHSO-5010 3-way connector and transformer mounted & wired in a sheetmetal enclosure):
 - NPS-120 120 Volt Supply Voltage
 - NPS-277 277 Volt Supply Voltage
 - NPS-240 240 Volt Supply Voltage
 - NPS-480 480 Volt Supply Voltage
4. Special Features: _____

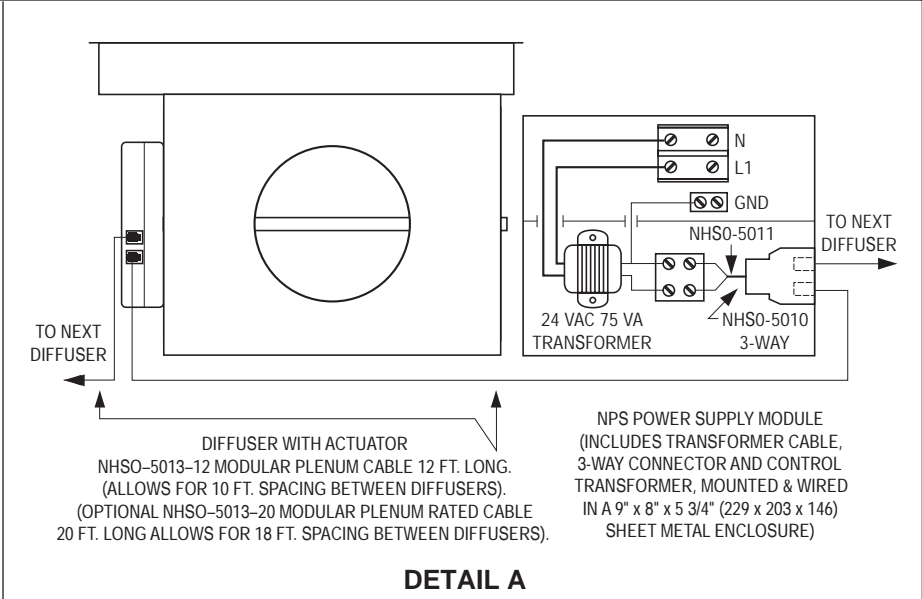

DETAIL A

NPS POWER SUPPLY MODULE (INCLUDES TRANSFORMER CABLE, 3-WAY CONNECTOR AND CONTROL TRANSFORMER, MOUNTED & WIRED IN A 9" x 8" x 5 3/4" (229 x 203 x 146) SHEET METAL ENCLOSURE)

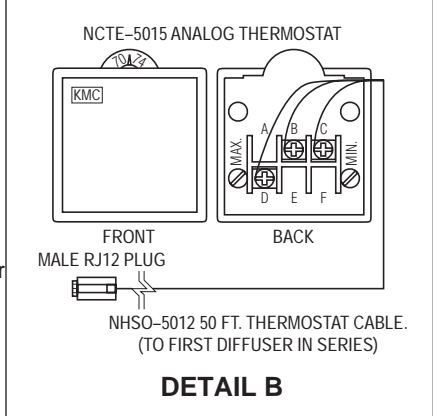

DETAIL B

SYSTEM OVERVIEW (SIDE VIEW):

A maximum of six actuators can be daisy chained on each side of a power supply module (4 actuators with optional 20 ft. cables). This allows a maximum of twelve actuators per power supply (8 actuators total with optional 20 ft. cables). Each thermostat can handle up to three power supply/actuator sub-systems for a total of up to thirty-six diffusers per thermostat, (24 diffusers with optional 20 ft. cables).

CONNECTION TO DDC CONTROLS:

The standard thermostat provides a direct acting 2 – 10 VDC control signal (Terminal D) to the actuator (Terminal B is Common). These wires can be connected to another signal source for control by the BMS. For heating only units a 2 VDC signal (or less) will drive the damper fully open (CW) to provide maximum airflow. Similarly a 10 VDC signal will drive the damper fully closed for ducted cooling.

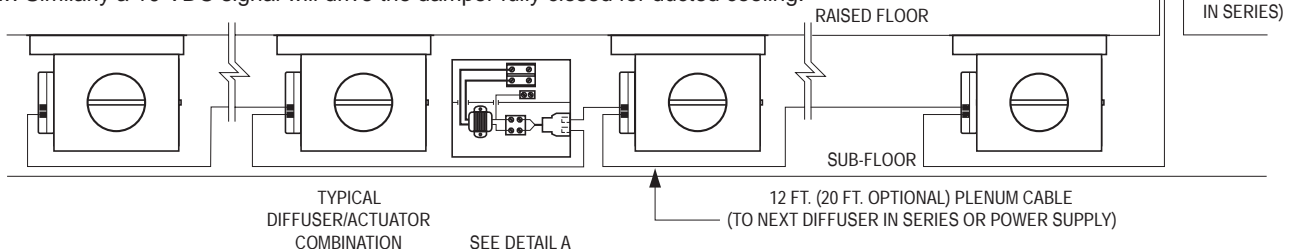

SCHEDULE TYPE:		Page 3 of 3			
PROJECT:		Dimensions are in inches (mm).			
ENGINEER:		DATE	B SERIES	SUPERSEDES	DRAWING NO.
CONTRACTOR:		2 - 12 - 07	NLD	8 - 30 - 05	NLD-VHCD