

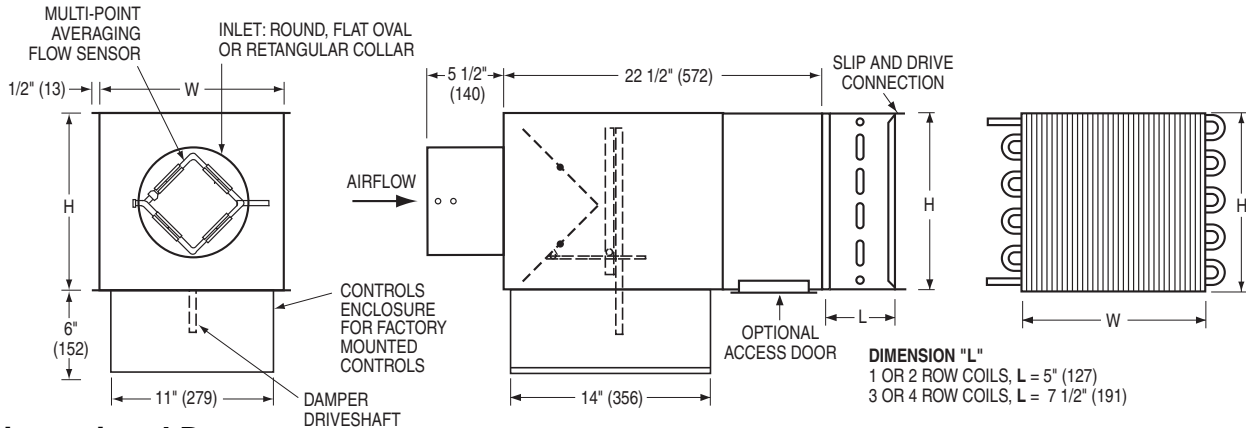

**SINGLE DUCT TERMINAL UNIT W/HOT WATER REHEAT
DIGITAL OR ANALOG CONTROLS • VARIABLE OR
CONSTANT VOLUME • PRESSURE INDEPENDENT
MODELS: D30RW AND A30RW WITH BOTTOM MOUNT
CONTROLS LOCATION (OPTION OB)**



Dimensional Data

Unit Size	Airflow Range cfm (l/s)	W	H	Inlet Size	Coil Connections			
					1 Row	2 Row	3 Row	4 Row
4	0 – 180 (0 – 85)	10 (254)	10 (254)	3 7/8 (98) Round	1/2 (13)	7/8 (22)	7/8 (22)	7/8 (22)
5	0 – 325 (0 – 153)	10 (254)	10 (254)	4 7/8 (124) Round	1/2 (13)	7/8 (22)	7/8 (22)	7/8 (22)
6	0 – 450 (0 – 212)	10 (254)	10 (254)	5 7/8 (149) Round	1/2 (13)	7/8 (22)	7/8 (22)	7/8 (22)
7	0 – 650 (0 – 307)	12 (305)	12 1/2 (318)	6 7/8 (175) Round	1/2 (13)	7/8 (22)	7/8 (22)	7/8 (22)
8	0 – 900 (0 – 425)	12 (305)	12 1/2 (318)	7 7/8 (200) Round	1/2 (13)	7/8 (22)	7/8 (22)	7/8 (22)
9	0 – 1150 (0 – 543)	14 (356)	12 1/2 (318)	8 7/8 (225) Round	1/2 (13)	7/8 (22)	7/8 (22)	7/8 (22)
10	0 – 1500 (0 – 708)	14 (356)	12 1/2 (318)	9 7/8 (251) Round	1/2 (13)	7/8 (22)	7/8 (22)	7/8 (22)
12	0 – 2050 (0 – 967)	18 (457)	12 1/2 (318)	12 15/16 x 9 13/16 (329 x 249) Oval	1/2 (13)	7/8 (22)	7/8 (22)	7/8 (22)
14	0 – 2550 (0 – 1203)	24 (610)	12 1/2 (318)	16 7/16 x 9 13/16 (408 x 249) Oval	1/2 (13)	7/8 (22)	7/8 (22)	7/8 (22)
16	0 – 3040 (0 – 1435)	28 (711)	12 1/2 (318)	19 3/16 x 9 13/16 (487 x 249) Oval	7/8 (22)	7/8 (22)	7/8 (22)	7/8 (22)
24 x 16	0 – 6800 (0 – 3209)	38 (965)	18 (457)	23 3/8 x 15 7/8 (606 x 403) Rect.	7/8 (22)	7/8 (22)	1 3/8 (35)	1 3/8 (35)

Standard Features:

- Bottom mount controls location with vertical drive shaft (option code OB).
- 22 ga. (0.86) zinc coated steel casing, mechanically sealed, low leakage construction.
- 16 ga. (1.63) corrosion-resistant steel inclined opposed blade damper with extruded PVC seals (single blade on size 4, 5, 6). 45° rotation, CW to close. Tight close-off. Damper leakage is less than 2% of the terminal rated airflow at 3" w.g. (750 Pa).
- 1/2" (13) dia. plated steel drive shaft. An indicator mark on the end of the shaft shows damper position.
- Multi-point averaging Diamond Flow Sensor. Aluminum construction. Supplied with balancing tees.
- Rectangular discharge with slip and drive cleat duct connection.

- Full NEMA type-1 controls enclosure for factory mounted controls.
- 3/4" (19), dual density insulation, exposed edges coated to prevent air erosion. Meets the requirements of NFPA 90A and UL 181.
- Hot Water Coil Section:**
- 1/2" (13) Copper tubes and aluminum ripple fins, 10 per inch.
- 1, 2, 3 or 4 row.
- Left or right hand connection. Determined by looking in direction of airflow (RH illustrated).
- 1/2" (13), 7/8" (22) or 1 3/8" (35) O.D. male solder sweat connections.
- Controls:**
- Digital (by others).
- Analog (by Nailor). See separate submittal.



Options and Accessories:

- Steri-liner.
- Fiber-free liner.
- Solid metal liner.
- 1" (25) liner.
- Bottom access door.
- 24 VAC control transformer.
- Toggle disconnect switch.
- Hanger brackets.
- Controls enclosure for field mounted controls.
- Dust tight enclosure seal.
- Special Features:

SCHEDULE TYPE	
PROJECT	
ENGINEER	
CONTRACTOR	

Page 1 of 2.
Dimensions are in inches (mm).

DATE	B SERIES	SUPERSEDES	DRAWING NO.
8 - 3 - 09	3000	12 - 1 - 08	D30RW-2

Integral Sound Attenuator plus Hot Water Coil

- Single continuous length terminal construction minimizes casing leakage.
- Continuous internal insulation reduces insulation seams and minimizes airflow disturbance.
- Supplied with same liner as basic unit.

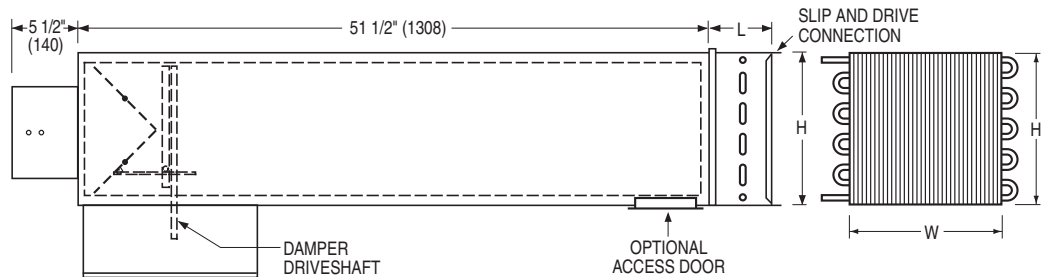

AT Discharge Sound Attenuator (loose)

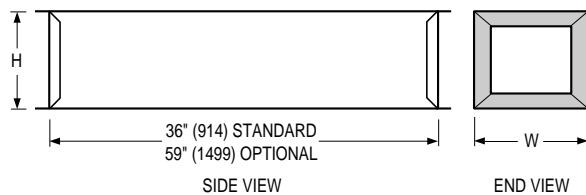

- Shipped loose for field attachment.
 - Slip and drive connection.
 - Supplied as standard with same liner as basic unit.
- AT303 Standard.
 AT305 Optional.
 Special Features: _____

FF Round Discharge Collar

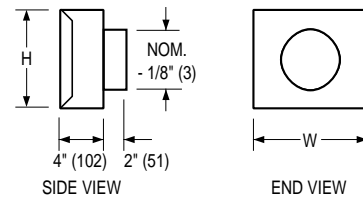

Dimensional Data

Unit Size	W	H	Hot Water Coil		FF Outlet Size
			L(1 & 2 row)	L(3 & 4 row)	
4, 5, 6	10 (254)	10 (254)	5 (127)	7 1/2 (191)	4, 5, 6 (102, 127, 152)
7, 8	12 (305)	12 1/2 (318)	5 (127)	7 1/2 (191)	7, 8 (178, 203)
9, 10	14 (356)	12 1/2 (318)	5 (127)	7 1/2 (191)	9, 10 (229, 254)
12	18 (457)	12 1/2 (318)	5 (127)	7 1/2 (191)	12 (305)
14	24 (610)	12 1/2 (318)	5 (127)	7 1/2 (191)	14 (356)
16	28 (711)	12 1/2 (318)	5 (127)	7 1/2 (191)	16 (406)
24 x 16	38 (965)	18 (457)	5 (127)	7 1/2 (191)	-

SCHEDULE TYPE

PROJECT

ENGINEER

CONTRACTOR

Page 2 of 2.
 Dimensions are in inches (mm).

DATE	B SERIES	SUPERSEDES	DRAWING NO.
8 - 3 - 09	3000	12 - 1 - 08	D30RW-2