

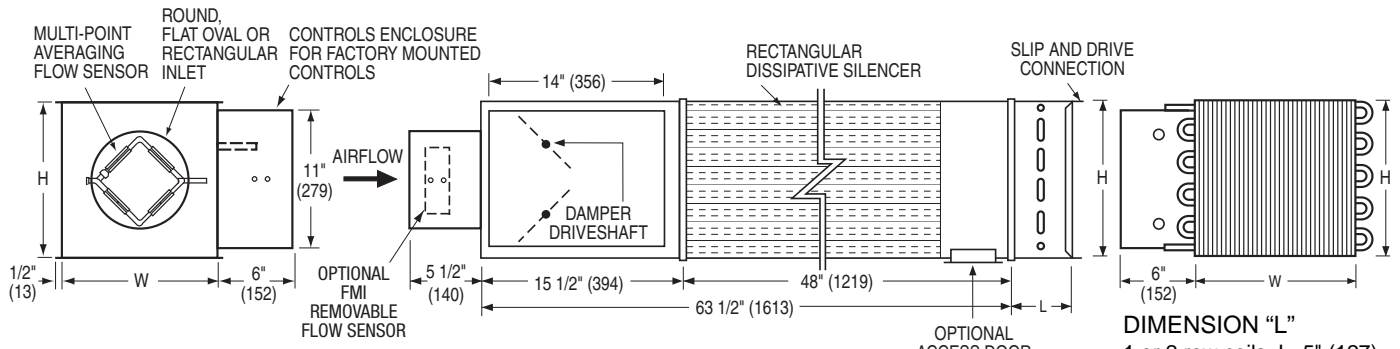

SINGLE DUCT TERMINAL UNIT WITH DISSIPATIVE SILENCER AND HOT WATER REHEAT • SUPER QUIET DIGITAL CONTROLS • VARIABLE OR CONSTANT VOLUME MODEL: D30RWQ



Dimensional Data

Unit Size	Airflow Range cfm (l/s)	W	H	Inlet Size	Coil Connections			
					1 Row	2 Row	3 Row	4 Row
4	0 – 180 (0 – 85)	10 (254)	10 (254)	3 7/8 (98) Round	1/2 (13)	7/8 (22)	7/8 (22)	7/8 (22)
5	0 – 325 (0 – 153)	10 (254)	10 (254)	4 7/8 (124) Round	1/2 (13)	7/8 (22)	7/8 (22)	7/8 (22)
6	0 – 450 (0 – 212)	10 (254)	10 (254)	5 7/8 (149) Round	1/2 (13)	7/8 (22)	7/8 (22)	7/8 (22)
7	0 – 650 (0 – 307)	12 (305)	12 1/2 (318)	6 7/8 (175) Round	1/2 (13)	7/8 (22)	7/8 (22)	7/8 (22)
8	0 – 900 (0 – 425)	12 (305)	12 1/2 (318)	7 7/8 (200) Round	1/2 (13)	7/8 (22)	7/8 (22)	7/8 (22)
9	0 – 1150 (0 – 543)	14 (356)	12 1/2 (318)	8 7/8 (225) Round	1/2 (13)	7/8 (22)	7/8 (22)	7/8 (22)
10	0 – 1500 (0 – 708)	14 (356)	12 1/2 (318)	9 7/8 (251) Round	1/2 (13)	7/8 (22)	7/8 (22)	7/8 (22)
12	0 – 2050 (0 – 967)	18 (457)	12 1/2 (318)	12 15/16 x 9 13/16 (329 x 249) Oval	1/2 (13)	7/8 (22)	7/8 (22)	7/8 (22)
14	0 – 2550 (0 – 1203)	24 (610)	12 1/2 (318)	16 1/8 x 9 13/16 (408 x 249) Oval	1/2 (13)	7/8 (22)	7/8 (22)	7/8 (22)
16	0 – 3040 (0 – 1435)	28 (711)	12 1/2 (318)	19 3/8 x 9 13/16 (487 x 249) Oval	7/8 (22)	7/8 (22)	7/8 (22)	7/8 (22)
24 x 16	90 – 6800 (0 – 3209)	38 (965)	18 (457)	23 7/8 x 15 1/8 (606 x 403) Rect.	7/8 (22)	7/8 (22)	1 3/8 (35)	1 3/8 (35)



Standard Features:

- Designed for noise sensitive applications such as classrooms, libraries, studios and performance halls.
- 22 ga. (0.86) zinc coated steel casing, mechanically sealed, low leakage construction.
- 16 ga. (1.63) corrosion-resistant steel inclined opposed blade damper with extruded PVC seals (single blade on size 4, 5, 6). 45° rotation, CW to close. Tight close-off. Damper leakage is less than 2% of the terminal rated airflow at 3" w.g. (750 Pa).
- 1/2" (13) dia. plated steel drive shaft. An indicator mark on the end of the shaft shows damper position.
- Multi-point averaging Diamond Flow Sensor. Aluminum construction. Supplied with balancing tees.
- Rectangular discharge with slip and drive cleat duct connection.
- Full NEMA 1 type controls enclosure for factory mounted controls.
- VAV section is lined with 3/4" (19), dual density insulation, exposed edges coated to prevent air erosion. Meets the requirements of NFPA 90A and UL 181.

- Right-hand controls location is standard (shown) when looking in direction of airflow. Optional left hand controls mounting is available.

Silencer Section:

- Designed to mate w/VAV section for optimum performance and super quiet operation.
- Optimized internal baffle geometry reduces self-generated noise, minimizes pressure drop and maximizes acoustic attenuation.
- 22 ga. (0.86) coated steel perforated baffles encapsulate fiberglass acoustic media.
- Internal Steri-Liner insulation on top and bottom optimizes sound reduction and eliminates need for external field applied thermal duct wrap.

Hot Water Coil Section:

- 1/2" (13) Copper tubes and aluminum ripple fins, 10 per inch.
- 20 ga. (1.00) zinc coated steel casing. Uninsulated.
- Left or right hand connection. Determined by looking in direction of airflow (RH illustrated).

- 1/2" (13), 7/8" (22) or 1 3/8" (35) O.D. male solder sweat connections.

Digital Controls (by others):

- Factory mount. (See separate submittal)
- Field mount.

Options and Accessories:

- Bottom access door.
- FMI Removable insert type Diamond Flow Sensor.
- 24 VAC control transformer.
- Toggle disconnect switch.
- Hanger brackets.
- Controls enclosure for field mounted controls.
- Dust tight enclosure seal.
- Special Features: _____

Terminal Unit Liner:

- Steri-liner.
- Steri-liner + Perforated metal liner.
- Fiber-free liner.
- Solid metal liner.
- Perforated liner.

Silencer Acoustic Media:

- Mylar/Spacer liner.
- Fiberglass Cloth liner.

Dimensions are in inches (mm).

SCHEDULE TYPE				
PROJECT				
ENGINEER			DATE	B SERIES
CONTRACTOR			SUPERSEDES	DRAWING NO.
			9 - 22 - 10	3000
			5 - 10 - 10	D30RWQ